

# Invacare® TDX® SP2 Series

TDXSP2, TDXSP2-CG, TDXSP2-MCG

## en Power Wheelchair Base User Manual



This manual **MUST** be given to the user of the product.  
**BEFORE** using this product, read this manual and save for future reference.



***Yes, you can.®***

© 2017 Invacare Corporation

All rights reserved. Republication, duplication or modification in whole or in part is prohibited without prior written permission from Invacare. Trademarks are identified by ™ and ®. All trademarks are owned by or licensed to Invacare Corporation or its subsidiaries unless otherwise noted.

Invacare reserves the right to alter product specifications without further notice.

Making Life's Experiences Possible is a registered trademark in the U.S.A.

---

# Contents

---

<b>1 General</b>	<b>5</b>
1.1 Introduction	5
1.2 Symbols	5
1.3 Prescription Statement	6
1.4 Intended Use	6
1.5 Indication for Use	6
1.6 Regulations	6
1.7 Service Life	6
<b>2 Safety</b>	<b>7</b>
2.1 General Guidelines	7
2.1.1 Set Up	11
2.1.2 Stairways and Escalators	13
2.1.3 Repair and Service Information — Providers and/or Qualified Technicians	14
2.2 Safety and Handling	15
2.3 A Note to Wheelchair Attendants	17
2.4 Stability and Balance	18
2.4.1 Driving Surfaces	19
2.4.2 Safety Information When Approaching Obstacles	19
2.4.3 The Correct Way to Approach Obstacles	20
2.4.4 Negotiating Inclines	21
2.4.5 Reaching, Leaning and Bending - Forward	22
2.4.6 Reaching, Leaning and Bending - Backward	23
2.4.7 Transferring To and From Other Seats	23
2.5 Pinch Points	24
2.6 Footplates and Front Rigging	25
2.7 Storage	25
2.8 Electrical	25
2.9 Recycling Batteries	26
2.10 Weight Training and Other Activities	26

<b>3 Electromagnetic Compatibility (EMC) Information</b>	<b>27</b>
3.1 Electromagnetic Interference (EMI) From Radio Frequency Sources	27
3.2 Powered Wheelchair Electromagnetic Interference (EMI)	27
3.3 Powered Wheelchair Electromagnetic Emissions	29
<b>4 Components</b>	<b>30</b>
4.1 Component Overview	30
4.2 Remotes	30
4.3 The Powered Seating System	30
4.4 Labels on the Product	32
<b>5 Setup</b>	<b>39</b>
5.1 Setup/Delivery Inspection	39
5.2 Adjusting Joystick Mount	39
<b>6 Usage</b>	<b>41</b>
6.1 Folding the Joystick Mount Up and Down	41
6.2 Pushing the Mobility Device in Freewheel Mode	41
6.2.1 Disengaging/Engaging the Motor Lock Levers	41
6.3 Disengaging/Engaging the Wheel locks	42
6.3.1 Engaging	42
6.3.2 Disengaging	42
<b>7 Controls System</b>	<b>43</b>
7.1 Controls Protection System	43
7.2 Batteries	43
7.2.1 General Information on Charging	43
7.2.2 General Instructions on Charging	43
7.2.3 How to Charge the Batteries	44
7.2.4 How to Disconnect the Mobility Device After Charging	46
7.2.5 Storage and Maintenance	46
7.2.6 Using the Proper Batteries	46
7.2.7 Instructions on Using the Batteries	48
7.2.8 Transporting Batteries	49
7.2.9 General Instructions on Handling the Batteries	49

7.2.10	How to Handle Damaged Batteries Correctly . . . . .	49	<b>10 After Use . . . . .</b>	<b>73</b>	
7.2.11	General Information on Battery Installation . . . . .	50	10.1	Reuse . . . . .	73
7.2.12	Removing the Batteries from the Wheelchair . . . . .	51	10.2	Disposal . . . . .	73
7.2.13	Installing Batteries into the Wheelchair . . . . .	52	<b>11 Troubleshooting . . . . .</b>	<b>74</b>	
7.2.14	Replacing Batteries and/or Battery Cables . . . . .	54	11.1	Driving Performance . . . . .	74
7.2.15	Cleaning Battery Terminals . . . . .	56	11.2	Control System . . . . .	74
<b>8 Transport . . . . .</b>	<b>57</b>		11.2.1	Battery and Charger Tips . . . . .	75
8.1	Wheelchair Transport Brackets (TRBKTS) . . . . .	57	<b>12 Technical Data . . . . .</b>	<b>77</b>	
8.2	Transport Ready Option (TRRO) . . . . .	57	12.1	Technical Specifications . . . . .	77
8.3	Transport—General information . . . . .	58	12.2	ISO 7176-15 Annex A . . . . .	81
8.4	Transferring Mobility Device to Vehicle . . . . .	59	<b>13 Warranty . . . . .</b>	<b>84</b>	
8.5	Use of the Mobility Device as a Seat in a Vehicle . . . . .	59	13.1	Limited Warranty—US . . . . .	84
8.5.1	How the Mobility Device is Anchored in a Vehicle . . . . .	61	13.2	Limited Warranty—Canada . . . . .	84
8.5.2	How The User is Secured Within the Mobility Device . . . . .	62	13.3	Repair or Replacement . . . . .	84
8.6	Transporting the Mobility Device Without Occupant . . . . .	64	13.4	Limitations and Exclusions . . . . .	85
<b>9 Maintenance . . . . .</b>	<b>65</b>		13.5	Disclaimers . . . . .	85
9.1	Wear and Tear Information . . . . .	65			
9.2	User/Attendant Inspection Checklists . . . . .	65			
9.2.1	Inspect/Adjust Weekly . . . . .	66			
9.2.2	Inspect/Adjust Monthly . . . . .	66			
9.2.3	Inspect/Adjust Periodically . . . . .	66			
9.3	Service Inspection . . . . .	66			
9.3.1	Six Month Inspection . . . . .	67			
9.3.2	Replace Every 18 Months . . . . .	68			
9.3.3	Replace Every 2 Years . . . . .	68			
9.4	Cleaning . . . . .	68			
9.5	Stability Lock . . . . .	69			
9.6	Removing/Installing the Shrouds . . . . .	70			
9.6.1	Removing the Rear Shroud . . . . .	70			
9.6.2	Installing the Rear Shroud . . . . .	70			
9.6.3	Removing/Installing the Front Shroud/Battery Retention Bracket . . . . .	70			
9.7	Wheels and Tires . . . . .	71			

---

# 1 General

---

## 1.1 Introduction

Thank you for choosing an Invacare product.

This user manual contains important information about the handling of the product. In order to ensure safety when using the product, read the user manual carefully and follow the safety instructions.

Before reading this manual, make sure you have the latest version. You can find the latest version as a pdf on the Invacare website (see back page of this manual). If you find that the font size in the print version of the user manual is difficult to read, you can download the pdf from the website. The pdf can then be scaled on screen to a font size that is more comfortable for you.

The decision whether the model is suitable for the user may only be taken by medical specialists with appropriate expertise.

Some maintenance and settings can be performed by the user or his/her attendants. Certain adjustments do however require technical training and may only be carried out by your Invacare qualified service technician. Refer to the Inspection checklists in *9 Maintenance, page 65*. Damages and errors caused by nonobservance of the user manual or as a result of incorrect maintenance are excluded from all warranties.

For more information about the product, contact your local Invacare representative. For address and website see the end of this manual.

## 1.2 Symbols

Signal symbols and/or words are used in this manual and apply to hazards or unsafe practices which could result in personal injury or property damage. See the information below for definitions of the signal words.



### **DANGER!**

– Danger indicates an imminently hazardous situation which, if not avoided, will result in death or serious injury.



### **WARNING!**

– Warning indicates a potentially hazardous situation which, if not avoided, could result in death or serious injury.



### **CAUTION!**

– Caution indicates a potentially hazardous situation which, if not avoided, may result in property damage or minor injury or both.



### **IMPORTANT**

– Indicates a hazardous situation that could result in damage to property if it is not avoided.





Gives useful tips, recommendations and information for efficient, trouble-free use.





This symbol identifies a list of various tools, components and items which you will need in order to carry out certain work.

---

## Symbols in the Manual

	Battery Recycling Symbol — Lead Acid
	Recycle this product. Refer to Disposal and Recycling sections.
	Manufacturer

## Symbols on the Product

	Read Manual
 <small>ISO 7176-19</small>	ISO 7176–19 Compliance — Refer to <i>8.2 Transport Ready Option (TRRO)</i> , page 57.
 <small>ISO 7176-19</small>	ISO 7176–19 Non-Compliance — Refer to <i>8.1 Wheelchair Transport Brackets (TRBKTS)</i> , page 57.

## 1.3 Prescription Statement

Per 21 CFR 801.109(b)(1) the device is labeled for prescription use only.



### CAUTION!

Federal Law (USA) restricts this device to sale by or on the order of a licensed physician.

## 1.4 Intended Use

The intended use of the device is to provide mobility and positioning to persons limited to a sitting position.

## 1.5 Indication for Use

The indication for use of the Invacare® TDX® SP2 Power Wheelchair is to provide mobility and positioning to persons limited to a sitting position.

## 1.6 Regulations

The vehicle was successfully tested according to international standards as to its safety. It satisfies the requirements according to RoHS 2011/65/EU, CAL117, ISO 7176–series.

It was also tested successfully according to EN 60529 IPX4 as to its resistance to spray water.

## 1.7 Service Life

The expected service life is five years, presuming that the product is used daily and in accordance with safety instructions, maintenance instructions and intended use, stated in this manual.

## 2 Safety

### 2.1 General Guidelines

The safety section contains important information for the safe operation and use of this product.

**WARNING!****Risk of Death, Injury or Damage**

Improper use of this product may cause injury or damage.

- If you are unable to understand the warnings, cautions or instructions, contact a health care professional or Provider before attempting to use this equipment.
- DO NOT use this product or any available optional equipment without first completely reading and understanding these instructions and any additional instructional material such as user manual, service manuals or instruction sheets supplied with this product or optional equipment.

**WARNING!****Risk of Death, Injury or Damage**

Continued use of the product with damaged parts could lead to the product malfunctioning, causing injury to the user and/or caregiver.

- Check all product components and carton for damage and test components before use. In case of damage or if the product is not working properly, stop using the product and contact a qualified technician or Invacare for repair.

**WARNING!****Risk of Serious Injury or Damage**

Use of unapproved accessories may result in serious injury or damage.

- Invacare products are specifically designed and manufactured for use in conjunction with approved Invacare accessories. Unapproved accessories have not been tested by Invacare for use with Invacare products.
- DO NOT use unapproved accessories.
- To obtain approved Invacare accessories, contact Invacare by phone or at [www.invacare.com](http://www.invacare.com).



**DANGER!**

**Risk of Death, Serious Injury, or Damage**

Use of incorrect or improper replacement (service) parts may cause death, serious injury, or damage.

- Replacement parts **MUST** match original Invacare parts.
- **ALWAYS** provide the wheelchair serial number to assist in ordering the correct replacement parts.



**DANGER!**

**Risk of Death, Serious Injury, or Damage**

Lighted cigarettes dropped onto an upholstered seating system can cause a fire resulting in death, serious injury, or damage.

- Wheelchair occupants are at particular risk of death or serious injury from these fires and resulting fumes because they may not have the ability to move away from the wheelchair.
- **DO NOT** smoke while using this wheelchair.



**WARNING!**

**Risk of Serious Injury or Damage**

Hardware that is loosely secured could cause loss of stability resulting in serious injury or damage.

- After **ANY** adjustments, repair or service and before use, make sure that all attaching hardware is tightened securely.



**WARNING!**

**Risk of Injury, Damage or Death**

Improper monitoring or maintenance may cause injury, damage or death due to ingestion or choking on parts or materials.

- Closely supervise children, pets, or people with physical/mental disabilities.



**WARNING!**

**Risk of Serious Injury or Damage**

Loss of power due to loose electrical connections could cause the wheelchair to suddenly stop resulting in serious injury or damage.

- **ALWAYS** ensure that all electrical connections are tightly connected so they don't vibrate loose.



**WARNING!****Risk of Injury or Damage**

Improper mounting or maintenance of the Sip-n-Puff control including the mouthpiece and breath tube may cause injury or damage.

Water inside the Sip-n-Puff interface module may cause damage to the unit.

Excessive saliva residue in the mouthpiece/straw can reduce performance.

Blockages, a clogged saliva trap or air leaks in the system may cause Sip-n-Puff not to function properly.

- Ensure moving parts of the wheelchair, including the operation of powered seating, DO NOT pinch or damage the Sip-n-Puff tubing.
- Saliva trap MUST be installed to reduce risk of water or saliva entering the Sip-n-Puff interface module.
- Occasionally flush the mouthpiece to remove saliva residue.
- The mouthpiece/straw MUST be completely dry before installation.
- If Sip-n-Puff does not function properly, inspect system for blockages, clogged saliva trap or air leaks. As necessary, replace mouthpiece, breath tube and saliva trap.

**WARNING!****Risk of Injury, Damage or Death**

Exposure to liquids may cause injury, damage or death.

- DO NOT expose electrical connections to sources of liquid or dampness. This includes, but is not limited to, water, body fluids or cleaning agents.
- DO NOT expose battery charger or other accessories to sources of liquid or dampness.
- Wheelchairs that are used by incontinent users and/or are frequently exposed to water/liquids may require replacement and inspection of electrical components more frequently than normal schedule dictates.
- Electrical components damaged by corrosion MUST be replaced immediately.



Contact your Invacare provider for more information about maintaining and troubleshooting the Sip-n-Puff system.



**CAUTION!**

**Risk of Damage**

Operating the wheelchair in rain or dampness may cause the wheelchair to malfunction electrically and mechanically, may cause the wheelchair to prematurely rust or may damage the upholstery.

- DO NOT leave wheelchair in a rain storm of any kind.
- DO NOT use wheelchair in a shower.
- DO NOT leave wheelchair in a damp area for any length of time.
- Check to ensure that the battery covers are secured in place, joystick boot is NOT torn or cracked where water can enter and that all electrical connections are secure at all times. DO NOT use if the joystick boot is torn or cracked. If the joystick boot becomes torn or cracked, replace IMMEDIATELY.



**WARNING!**

**Risk of Injury or Damage**

Use of the power wheelchair outside of specified operating conditions may cause unintended or erratic movement. This may include, but is not limited to impacts and sudden stops. To avoid injury or damage:

- Only use the power wheelchair in the operating conditions specified in the Technical Data chapter of this manual.



THE INFORMATION CONTAINED IN THIS DOCUMENT IS SUBJECT TO CHANGE WITHOUT NOTICE.



As a manufacturer of wheelchairs, Invacare endeavors to supply a wide variety of wheelchairs to meet many needs of the end user. However, final selection of the type of wheelchair to be used by an individual rests solely with the user and his/her healthcare professional capable of making such a selection. Invacare recommends working with a qualified rehab technology provider, such as an ATP, (Assistive Technology Professional).

### 2.1.1 Set Up

**DANGER!****Risk of Death, Serious Injury, or Damage**

Continued use of the wheelchair that is not set to the correct specifications may cause erratic behavior of the wheelchair resulting in death, serious injury, or damage.

- Performance adjustments should only be made by professionals of the healthcare field or persons fully conversant with this process and the driver's capabilities.
- After the wheelchair has been set up/adjusted, check to make sure that the wheelchair performs to the specifications entered during the set up procedure. If the wheelchair does not perform to specifications, turn the wheelchair Off immediately and reenter set up specifications. Contact Invacare, if wheelchair still does not perform to correct specifications.

**WARNING!****Risk of Serious Injury or Damage**

Moving the seating system from the factory setting may reduce driver control, wheelchair stability, traction and increase caster wear resulting in serious injury or damage.

- Move the seating system **ONLY** when necessary to fit the wheelchair to the user.
- If the seating system must be moved, **ALWAYS** inspect the wheelchair to ensure the front rigging **DOES NOT** interfere with the front casters.
- If the seating system must be moved, **ALWAYS** inspect to ensure the wheelchair **DOES NOT** easily tip forward or backward.

**WARNING!****Risk of Injury, Damage or Death**

Improper routing of cable(s) may cause tripping, entanglement or strangulation hazard that may result in injury, damage or death.

- Ensure all cable(s) are routed and secured properly.
- Ensure there are no loops of excess cable extending away from the chair.
- Close supervision and attention is needed when operating the wheelchair near children, pets or people with physical/mental disabilities.



**WARNING!**

**Risk of Injury, Damage or Death**

Pinched or severed cable(s) may be a shock or fire hazard and may cause injury, damage or death.

- Ensure all cable(s) are routed and secured properly.
- Inspect cable(s) periodically for proper routing, pinching, chafing or other similar wear.
- Replace any damaged cables immediately.



**WARNING!**

**Risk of Serious Injury**

Sharp edges can cause serious injury.

- Be mindful that some parts may have sharp edges. Use caution when encountering these sharp edges.



**WARNING!**

**Risk of Serious Injury**

Hot surfaces can cause severe burns.

- Be mindful of potential hot surfaces and avoid touching.



**WARNING!**

- DO NOT connect any medical devices such as ventilators, life support machines, etc. directly to the batteries used to power the wheelchair. This could cause unexpected failure of the device and the wheelchair.



**WARNING!**

**Risk of Injury or Damage**

Grease may leak from the gearbox and cause injury or damage from falling or fire.

- Follow the maintenance instructions in this manual.
- Routinely inspect the gearbox for grease leakage.

If the gearbox is leaking grease:

- Stop use immediately.
- Keep the product away from sparks, flame, and open heat sources.
- Contact your provider or Invacare for repair.



**DANGER!**

**Risk of Death, Serious Injury, or Damage**

Missing attaching hardware could cause instability resulting in death, serious injury or damage.

- Ensure all attaching hardware is present and tightened securely.

## 2.1.2 Stairways and Escalators



### WARNING!

#### Risk of Injury, Damage or Death

Improper use on stairways and escalators may cause injury, damage or death.

- DO NOT attempt to move an occupied wheelchair between floors using a stairway or escalator.
- DO NOT attempt to move an empty power wheelchair between floors using an escalator.
- Observe and follow all safety warnings.
- Use instructions provided for safe transportation between floors.



### WARNING!

#### Risk of Injury or Damage

Improper lifting technique may cause injury or damage.

- Use proper lifting techniques, assistance and gear such as straps when available when lifting heavy loads.



When using a stairway to move the wheelchair and any accessories, move all wheelchair components away from the stairway prior to reassembly.

- Follow this procedure for moving the wheelchair between floors when an elevator is NOT available:
  1. If stairway or escalator is only means of access, remove occupant of wheelchair and transport user and wheelchair separately.
  2. Invacare recommends using two attendants and making thorough preparations prior to transportation.
  3. Ensure that only secure, non-detachable parts are used for hand-hold supports.
  4. Use safe lifting techniques.
  5. Remove the batteries from wheelchair. Refer to *7.2.12 Removing the Batteries from the Wheelchair, page 51*.
  6. Using non-removable (non-detachable) parts of the wheelchair, lift the wheelchair off of the ground and transfer the wheelchair up or down the stairs.
  7. The wheelchair should not be lowered until the last stair has been negotiated and the wheelchair has been carried away from the stairway.

- Use an elevator or other accepted safe means of transportation between floors.
- Extreme caution is advised when it is necessary to move an unoccupied power wheelchair up or down the stairs.

### 2.1.3 Repair and Service Information — Providers and/or Qualified Technicians



#### **DANGER!**

#### **Risk of Injury, Damage or Death**

Improper setup, service, adjustment or programming may cause injury, damage or death.

- Qualified technician **MUST** setup, service and program the wheelchair.
- **DO NOT** allow non-qualified individuals to perform any work or adjustments on the wheelchair.
- **DO NOT** setup or service the wheelchair while occupied except for programming or unless otherwise noted.
- Turn off power **BEFORE** adjusting or servicing the wheelchair. Note that some safety features will be disabled.
- Ensure all hardware is securely tightened after setup, service or adjustments.
- Warranty is void if non-qualified individuals perform any work on this product.



#### **DANGER!**

#### **Risk of Death, Serious Injury, or Damage**

Corroded electrical components due to water and/or liquid exposure, or incontinent users can result in death, serious injury, or damage.

- Minimize exposure of electrical components to water and/or liquids. Electrical components damaged by corrosion **MUST** be replaced immediately.
- Wheelchairs that are used by incontinent users and/or are frequently exposed to water/liquids may require replacement of electrical components more frequently.



#### **WARNING!**

- **DO NOT** overtighten hardware attaching to the frame. This could cause damage to the frame tubing.
- Replace gas-locking cylinders every two years or if performance issues are encountered. Performance issues include forward tipping and veering.



#### **WARNING!**

#### **Risk of Injury, Damage or Death**

Improper installation or service may result in injury, damage or death.

- Transport ready packages are not retrofittable to existing models and are not field serviceable.
- **DO NOT** overtighten hardware.

## 2.2 Safety and Handling

Safety and handling of the wheelchair requires the close attention of the wheelchair user as well as the assistant. This manual points out the most common procedures and techniques involved in the safe operation and maintenance of the wheelchair. It is important to practice and master these safe techniques until you are comfortable in maneuvering the wheelchair.

Users and attendants must be aware that the handling and maneuverability characteristics of the wheelchair are inherently different based on the drive wheel location. Handling and maneuverability differences will be most noticeable when traveling down declines (Example: ramps and slopes) or over obstacles and rough terrain as this may shift the users center of mass forward resulting in decreased stability. ALWAYS reduce speed and wear the seat positioning strap when driving under these conditions.

Individual wheelchair users often develop skills to deal with daily living activities that may differ from those described in this manual. Invacare recognizes and encourages each individual to try what works best for him/her in overcoming obstacles that they may encounter. However all warnings and cautions given in this manual MUST be followed. Techniques in this manual are a starting point for the new wheelchair user and assistant with “safety” as the most important consideration for all.

Invacare strongly recommends that initial use of wheelchairs be supervised by an assistant.



### **DANGER!**

#### **Risk of Death, Serious Injury, or Damage**

Misuse of the wheelchair may cause component failure and/or the wheelchair to start smoking, sparking, or burning. Death, serious injury, or damage may occur due to fire.

- DO NOT use the wheelchair other than its intended purpose. If the wheelchair starts smoking, sparking, or burning, discontinue using the wheelchair and seek service IMMEDIATELY.



### **DANGER!**

#### **Risk of Death or Serious Injury**

Not wearing your seat positioning strap could result in death or serious injury.

- ALWAYS wear your seat positioning strap. Your seat positioning strap helps reduce the possibility of a fall from the wheelchair. The seat positioning strap is a positioning belt only. It is not designed for use as a safety device withstanding high stress loads such as auto or aircraft safety belts. If signs of wear appear, seat positioning strap MUST be replaced IMMEDIATELY.



**WARNING!**

**Risk of Injury, Damage or Death**

Use of the wheelchair while judgement or ability is impaired may result in injury, damage or death.

- DO NOT operate the wheelchair under the influence of alcohol, medications or other substances that impair judgement or function.
- Changing medications may affect your ability to operate the wheelchair. Discuss the impact on your ability to operate the wheelchair with a health care professional when changing medications.
- DO NOT operate the wheelchair under conditions where judgement or function may be impaired. This may include but is not limited to lack of sleep or poor sight.
- Always be aware of your surroundings.



**WARNING!**

**Risk of Injury, Damage or Death**

Misuse of wheelchair may result in injury, damage or death.

- Use care when operating the wheelchair on roads, streets or other roadways.
- Use care when operating the wheelchair when vision is impaired by poor lighting such as unlit rooms, during the night or similar situations.
- ALWAYS be aware of motor vehicles and your surroundings.



**WARNING!**

**Risk of Injury, Damage or Death**

Conditions such as restlessness, mental deterioration, dementia, seizure disorders (uncontrolled body movement) or sleeping problems may cause injury, damage or death.

- Monitor patients with these conditions frequently.
- Close supervision and attention is needed when operating the wheelchair near children, pets or people with physical/mental disabilities.



**WARNING!**

**Risk of Injury or Damage**

To avoid injury or damage from moving parts:

- ALWAYS keep hands and fingers clear of moving parts.
- Closely supervise children, pets, or people with physical/mental disabilities.



**WARNING!****Risk of Injury or Damage**

Improper operation may change the normal balance, center of gravity or weight distribution of the wheelchair causing injury or damage.

- Determine and establish your particular safety limits. Practice bending, reaching and transferring activities in several combinations in the presence of a qualified healthcare professional before attempting active use of the wheelchair.
- ALWAYS shift your weight in the direction you are turning. Shifting your weight in the opposite direction of the turn may cause the inside drive wheel to lose traction.

**WARNING!****Risk of Serious Injury**

Impacting objects in the surrounding environment can cause serious injury.

- When maneuvering the wheelchair around, ALWAYS have assured cleared distance with all objects in environment.

**WARNING!**

- Always check grips for looseness before using the wheelchair. If loose, contact a qualified technician for instructions.

**WARNING!****Risk of Injury or Damage**

Unintended movement or operation of wheelchair may cause injury or damage.

- Turn power OFF BEFORE entering or exiting the wheelchair.
- Close supervision and attention is needed when operating the wheelchair near children pets or people with physical/mental disabilities. Turn power off.

**WARNING!****Risk of Injury, Damage or Death**

Damaged parts due to collision or impact may result in injury, damage or death.

- Seek immediate attention and service if wheelchair is involved in a collision or impact event. This includes, but is not limited to, vehicle accidents, mishandling and impact events where the wheelchair strikes something or is struck by something that may cause damage.
- Ensure your wheelchair is working properly and is inspected by a qualified Invacare technician if the wheelchair is involved in a collision or impact event.

## 2.3 A Note to Wheelchair Attendants

When assistance to the wheelchair user is required, remember to use good body mechanics. Keep your back straight and bend your knees whenever tilting wheelchair or traversing curbs or other impediments.

Ensure that only secure, non-detachable parts are used for hand-hold supports.

When learning a new assistance technique, have an experienced attendant help you before attempting it alone.

## 2.4 Stability and Balance

To assure stability and proper operation of your wheelchair, you **MUST** at all times maintain proper balance. Your wheelchair has been designed to remain upright and stable during normal daily activities as long as you **DO NOT** move beyond the center of gravity. **DO NOT** lean forward out of the wheelchair any further than the length of the armrests.

The drive behavior initially experienced by the user may be different from other wheelchairs previously used. This power wheelchair has Invacare's SureStep® technology, a feature that provides the wheelchair with optimum traction and stability when driving forward over transitions and thresholds. Refer to *12 Technical Data, page 77* for maximum height of transitions and thresholds. For more information about approaching obstacles refer to *2.4.2 Safety Information When Approaching Obstacles, page 19* and *2.4.3 The Correct Way to Approach Obstacles, page 20*.



### **WARNING!**

#### **Risk of Injury, Damage or Death**

Improper use of wheelchair may cause instability and may result in injury, damage or death. The stability of the wheelchair is adversely affected by additional weight that shifts the center of gravity.

- This wheelchair has been designed to accommodate one individual. **DO NOT** operate with additional person(s).
- **DO NOT** carry heavy objects on your lap while operating the wheelchair.

**WARNING!****Risk of Injury or Damage**

Improper position and activity, such as reaching, bending or transferring may change the normal balance, center of gravity or weight distribution of the wheelchair causing injury or damage.

- Observe and follow all instructions and warnings regarding reach, weight, balance and positioning.
- Determine and establish your particular safety limits. Practice bending, reaching and transferring activities in several combinations in the presence of a qualified healthcare professional before attempting active use of the wheelchair.
- DO NOT move beyond the center of gravity.
- DO NOT lean forward out of the wheelchair any further than the length of the armrests.
- DO NOT attempt to reach objects if you have to move forward in the seat or pick them up from the floor by reaching down between your knees.
- DO NOT shift your weight or sitting position toward the direction you are reaching.
- DO NOT stand on the frame of the wheelchair.
- DO NOT lean over the top of the back of the wheelchair.

**2.4.1 Driving Surfaces****WARNING!****Risk of Injury, Damage or Death**

Loss of traction or stability on rough or unstable terrain may cause injury, damage or death.

- Use care when operating the wheelchair on rough or unstable terrain. This would include but is not limited to areas of rock, mulch, mud, uneven pavement, roots and similar conditions.
- Be aware of your surroundings and conditions that might affect the ability to operate the wheelchair.

Your power wheelchair has been designed to operate on firm, dry, level surfaces (such as, interior floors, concrete and asphalt). Other acceptable surfaces likely to be encountered include packed soil, grass, and gravel.



Do not operate the wheelchair in any type or depth of water (edges of streams, lakes, or oceans.)

If you approach an unfamiliar surface and feel uneasy about driving on that surface, avoid that surface.

**2.4.2 Safety Information When Approaching Obstacles**

Approach obstacles safely by learning to manage your wheelchair. Keep in mind your center of gravity to maintain stability and balance.

While the wheelchair is designed for use primarily in and around the home, the provider should determine whether this wheelchair is suitable for the actual environment in which the wheelchair will be used.

**WARNING!****Risk of Injury, Damage or Death**

Loss of traction or stability on curbs/obstacles may cause injury, damage or death.

- DO NOT cross curbs/obstacles that are not suitable for wheelchairs.
- DO NOT attempt to pass curbs/obstacles that are greater than the maximum climbable obstacle height.
- Follow all instructions regarding negotiating curbs, obstacles and inclines.



Maximum climbable obstacle height is listed in 12 *Technical Data*, page 77.

**CAUTION!****Risk of Injury or Damage**

The wheelchair may tip over if obstacles are not approached correctly.

- Always approach obstacles straight on. Never approach at an angle, as shown in the following image.
- Approach obstacles followed by a gradient with caution. If unsure whether the gradient is too steep or not, move away from the obstacle and if possible try to find another location.
- Put your backrest into an upright position before ascending an obstacle.

**CAUTION!****Risk of Injury or Damage**

There is a risk of falling out of the mobility device if obstacles are not approached correctly. There is also a risk of damage to the mobility device, such as broken casters.

- Never approach obstacles that are higher than the maximum climbable obstacle height.
- Never let the footrest/legrest touch the ground when descending an obstacle.
- If unsure whether taking an obstacle is possible or not, move away from the obstacle and if possible find another location.

**2.4.3 The Correct Way to Approach Obstacles**

The following instructions for approaching obstacles also apply to attendants if the mobility device is equipped with an attendant control.

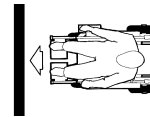

Fig. 2-1 Right

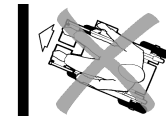

Fig. 2-2 Wrong

**Ascending (Going Up) Obstacles**

1. Move the backrest into an upright position and lower the seat to the lowest position using the powered seating functions, if equipped.
2. Approach the obstacle or the curb slowly, head-on and at a right angle (or 90°) to the obstacle.

3. Stop in the following position: 2–4 inches (5 - 10 cm) before the obstacle.
4. Check the position of the front wheels. They must be in driving direction and at right angles to the obstacle.
5. Approach slowly and keep at a consistent speed until the rear wheels have also passed over the obstacle.

### Descending (Going Down) Obstacles

The approach to descend an obstacle is the same as to ascend it, with the difference that you do not need to stop before descending.

1. Descend the obstacle with medium speed.
  -  Descending an obstacle too slowly could cause the antitippers to get stuck and lift the drive wheels off the ground. Driving the mobility device is then no longer possible.

### 2.4.4 Negotiating Inclines

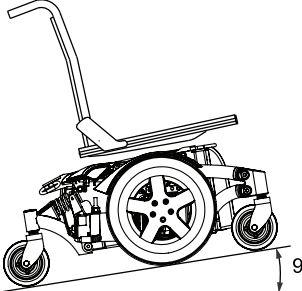
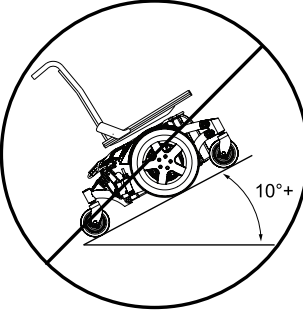
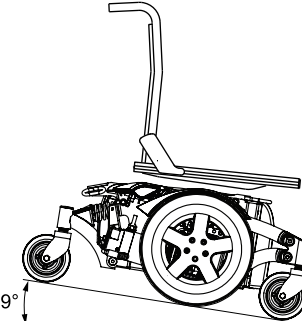
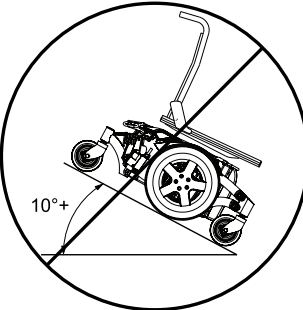
Acceptable Incline Angles 0° to 9°	Avoid Inclines of 10° and above
 <p style="text-align: center;">Fig. 2-3</p>	 <p style="text-align: center;">Fig. 2-4</p>
 <p style="text-align: center;">Fig. 2-5</p>	 <p style="text-align: center;">Fig. 2-6</p>

**WARNING!****Risk of Injury, Damage or Death**

Loss of traction or stability on inclines/grades or ramps may cause injury, damage or death. Lighter weight users may be at an increased risk. Surfaces that may be wet, icy, oily, slippery, painted, treated wood, rotten wood, rusted metal or other similar surfaces or materials may also increase risk.

- DO NOT use on inclines or ramps where surface is uncertain or compromised.
- DO NOT use on inclines greater than nine (9) degrees.
- DO NOT operate the seating system while on an incline. Operation on an incline may result in increased instability.
- To determine and establish your particular safety limits, practice use of this product on various sloping surfaces in the presence of a qualified healthcare provider before attempting active use of this wheelchair.
- DO NOT use on inclines where line of sight is impaired.
- Travel at a reduced, constant speed and DO NOT make sudden stops or direction changes. Release the joystick and allow the wheelchair to come to a full stop before changing directions. Traveling at high speeds reduces traction and increases stopping distance.

**WARNING!****Risk of Injury, Damage or Death**

Loss of traction or stability on inclines/grades or ramps may cause injury, damage or death. Lighter weight users may be at an increased risk. Surfaces that may be wet, icy, oily, slippery, painted, treated wood, rotten wood, rusted metal or other similar surfaces or materials may also increase risk.

- DO NOT drive in an elevated position while on an incline.
- DO NOT leave elevating legrests in the fully extended position when proceeding down inclines/grades.
- DO NOT leave an unoccupied wheelchair unattended on inclines or ramps.

**DANGER!****Risk of Death or Serious Injury**

Traveling down inclines in reverse could cause the wheelchair to tip over resulting in death or serious injury

- DO NOT travel down inclines in reverse.

**2.4.5 Reaching, Leaning and Bending - Forward**

Many activities require the wheelchair user to reach, bend and transfer in and out of the wheelchair. These movements will cause a change to the normal balance, center of gravity, and weight distribution of the wheelchair. To determine and establish your particular safety limits, practice bending, reaching and transferring activities in several combinations

in the presence of a qualified healthcare professional before attempting active use of the wheelchair



Fig. 2-7

Ensure the motor locks are engaged (not in freewheel mode) and turn power off before reaching, leaning or bending. Bend only as far as your arm will extend without changing your sitting position. Casters should be parallel to the drive wheel.

#### 2.4.6 Reaching, Leaning and Bending - Backward



Fig. 2-9

Position wheelchair as close as possible to the desired object. Position the casters so that they are extended

60101831-B



Fig. 2-8

away from the drive wheels to create the longest possible wheelbase, engage the motor locks and turn power off. Reach back only as far as your arm will extend without changing your sitting position.

#### 2.4.7 Transferring To and From Other Seats



##### **WARNING!**

##### **Risk of Serious Injury or Damage**

Improper transfer techniques may cause serious injury or damage.

- Before attempting transfers, consult a health care professional to determine proper transfer techniques for the user and type of wheelchair.



##### **WARNING!**

##### **Risk of Injury or Damage**

Misuse of footplate may cause injury or damage.

- DO NOT stand on footplates.
- Ensure the footplates are in the upward position or swung outward when getting in or out of the wheelchair.

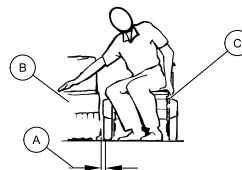

Fig. 2-10 Front View

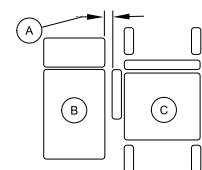



Fig. 2-11 Top View

 Adequate mobility and upper body strength is required to perform this activity independently.

1. Transfer to and from the wheelchair in the presence of a qualified healthcare professional to determine individual safety limits.
2. Turn power button OFF BEFORE entering or exiting the wheelchair.
3. Reduce gap between transfer surface **Ⓑ** and wheelchair seat **Ⓒ** to the minimum distance **Ⓐ** necessary to perform transfer.
4. ALWAYS ensure both motor locks are engaged and wheel hubs (if equipped) to prevent the wheels from moving before transferring into or from the wheelchair.
5. Align casters parallel to the drive wheels to improve stability during transfer.
6. Invacare strongly recommends ordering the optional wheel locks as an additional safeguard if not present.
7. Flip up footplates or swing footrests outward.
8. Shift body weight into seat with transfer

 During independent transfer, little or no seat platform will be beneath you. Use a transfer board if at all possible.

## 2.5 Pinch Points



### WARNING!

#### Risk of Minor to Serious Injury

Pinch points can cause minor to serious injury.  
 – Be mindful of potential pinch points and use caution when using this product.



### WARNING!

#### Risk of Injury

Pinch points can cause injury.

- Be aware that a pinch point **Ⓐ** exists between the head tube cap and walking beam.
- Be aware that a pinch point **Ⓑ** exists between the walking beam/head tube cap and telescoping tube when the wheelchair is at the lowest seat to floor height.
- Be aware that a pinch point **Ⓒ** may occur when rotating the center mount front rigging assembly.

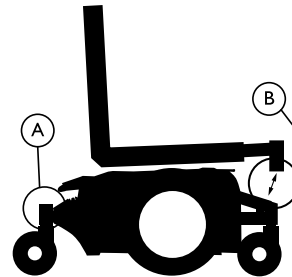

Fig. 2-12 Pinch Points — Head Tube Cap/Walking Beam and Telescoping Tube

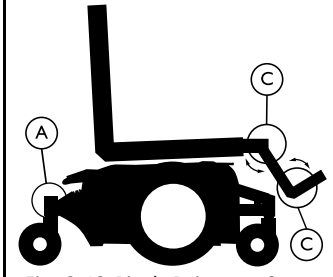

Fig. 2-13 Pinch Points — Center Mount Front Rigging



## 2.6 Footplates and Front Rigging



### **WARNING!**

#### **Risk of Serious Injury or Damage**

Operating the wheelchair with a clearance of less than 75 mm (3 inches) between the footplates and the ground/floor may cause serious injury or property damage.

- ALWAYS maintain a minimum of 75 mm (3 inches) between the bottom of the footplates and ground/floor to ensure proper clearance while the wheelchair is in motion. If necessary, adjust the footplates height to achieve proper clearance. After footplates height adjustment, if the wheelchair dips forward and the footplates touch the ground while in motion, please contact your provider for an inspection and avoid use of the wheelchair if possible.

## 2.7 Storage



### **WARNING!**

#### **Risk of Injury, Damage or Death**

Storage or use near heat sources and combustible products may result in injury or damage.

- DO NOT store or use wheelchair near open flames or other heat sources.
- DO NOT store or use wheelchair near combustible products.

## 2.8 Electrical



### **DANGER!**

#### **Risk of Death or Serious Injury**

Electric shock can cause death or serious injury  
 – To avoid electric shock, inspect plug and cord for cuts and/or frayed wires. Replace cut cords or frayed wires immediately.



### **WARNING!**

Power wheelchairs are equipped with three-prong (grounding) plugs for protection against possible shock hazards. Where a two-prong wall receptacle is encountered, it is the personal responsibility and obligation of the customer to contact a qualified electrician and have the two-prong replaced with a properly grounded three-prong wall receptacle in accordance with the National Electrical code. If you must use an extension cord, use only a three-wire extension cord having the same or higher electrical rating as the device being connected. DO NOT, under any circumstances, cut or remove the round grounding prong from any plug used with or for Invacare products. In addition, Invacare has placed RED warning tags on some equipment. DO NOT remove these tags.



**DANGER!**

**Risk of Death, Injury or Damage**

Shock hazards and risk of fire exist due to use of improper extension cord and/or use of three prong adapters.

- To avoid injury or product damage, when using an extension cord, use only a UL approved three wire extension cord having at least 16 AWG (American Wire Gauge) wire and the same or higher electrical rating as the device being connected.
- DO NOT use three prong to two prong adapters.

**2.9 Recycling Batteries**



Fig. 2-14



Fig. 2-15

Lead acid batteries are almost entirely recyclable. Discarding these batteries in the trash is considered “improper disposal” and is illegal in most states. Old, used batteries are “hazardous material” and MUST be recycled through an approved agency. Contact your provider or Invacare on proper disposal and recycling of your batteries.

**2.10 Weight Training and Other Activities**



**WARNING!**

**Risk of Injury or Damage**

Invacare DOES NOT recommend the use of its wheelchairs as a weight training apparatus. Invacare wheelchairs have NOT been designed or tested as a seat for any kind of weight training. Using said wheelchair for weight training could result in serious bodily injury to the user, damage to the wheelchair and surrounding property. Also, if occupant uses said wheelchair as a weight training apparatus, Invacare shall NOT be liable for bodily injury and the warranty is void.

- DO NOT use the wheelchair as a weight training apparatus.



**WARNING!**

**Risk of Injury or Damage**

Misuse of the wheelchair may result in injury or damage.

- DO NOT use the wheelchair for stretching exercises.
- DO NOT use the wheelchair to perform wheelies.

## 3 Electromagnetic Compatibility (EMC) Information

### 3.1 Electromagnetic Interference (EMI) From Radio Frequency Sources

Powered wheelchairs and motorized scooters (in this text, both will be referred to as mobility devices) may be susceptible to electromagnetic interference (EMI), which is interfering electromagnetic energy (EM) emitted from sources such as radio stations, TV stations, amateur radio (HAM) transmitters, two way radios, and cellular phones. The interference (from radio wave sources) can cause the mobility devices to release its brakes, move by itself, or move in unintended directions. It can also permanently damage the mobility devices control system. The intensity of the interfering EM energy can be measured in volts per meter (V/m). Each powered mobility device can resist EMI up to a certain intensity. This is called its "immunity level." The higher the immunity level, the greater the protection. At this time, current technology is capable of achieving at least a 20 V/m immunity level, which would provide useful protection from the more common sources of radiated EMI.

There are a number of sources of relatively intense electromagnetic fields in the everyday environment. Some of these sources are obvious and easy to avoid. Others are not apparent and exposure is unavoidable. However, we believe that by following the warnings listed below, your risk to EMI will be minimized.

The sources of radiated EMI can be broadly classified into three types:

1. Hand-held Portable transceivers (transmitters/receivers with the antenna mounted directly on the transmitting unit. Examples include: citizens band (CB) radios, "walkie talkie", security, fire and police transceivers, cellular telephones, and other personal communication devices).



Some cellular telephones and similar devices transmit signals while they are ON, even when not being used.

2. Medium-range mobile transceivers, such as those used in police cars, fire trucks, ambulances and taxis. These usually have the antenna mounted on the outside of the vehicle.
3. Long-range transmitters and transceivers, such as commercial broadcast transmitters (radio and TV broadcast antenna towers) and amateur (HAM) radios.



Other types of handheld devices, such as cordless phones, laptop computers, AM/FM radios, TV sets, CD players, cassette players, and small appliances, such as electric shavers and hair dryers, so far as we know, are not likely to cause EMI problems to your powered mobility device.

### 3.2 Powered Wheelchair Electromagnetic Interference (EMI)

Because EM energy rapidly becomes more intense as one moves closer to the transmitting antenna (source), the EM fields from handheld radio wave sources (transceivers) are of special concern. It is possible to unintentionally bring high levels of EM energy very close to the mobility devices control system while using these devices. This can affect the

mobility device's movement and braking. Therefore, the warnings listed below are recommended to prevent possible interference with the control system of the mobility device.

Electromagnetic interference (EMI) from sources such as radio and TV stations, amateur radio (HAM) transmitters, two-way radios, and cellular phones can affect powered wheelchairs and motorized scooters.

FOLLOWING THE WARNINGS LISTED BELOW SHOULD REDUCE THE CHANCE OF UNINTENDED BRAKE RELEASE OR POWERED WHEELCHAIR MOVEMENT WHICH COULD RESULT IN SERIOUS INJURY.



**WARNING!**

- DO NOT operate handheld transceivers (transmitters receivers), such as citizens band (CB) radios, or turn ON personal communication devices, such as cellular phones, while the mobility device is turned ON;
- Be aware of nearby transmitters, such as radio or TV stations, and try to avoid coming close to them;
- If unintended movement or brake release occurs, turn the mobility device OFF as soon as it is safe;
- Be aware that adding accessories or components, or modifying the mobility device, may make it more susceptible to EMI (Note: There is no easy way to evaluate their effect on the overall immunity of the mobility device); and
- Report all incidents of unintended movement or brake release to Invacare and note whether there is a source of EMI nearby.

**WARNING!****Important Information**

- 20 volts per meter (V/m) is a generally achievable and useful immunity level against EMI (as of May 1994) (the higher the level, the greater the protection);
- This device has been tested to a radiated immunity level of 20 volts per meter.
- The immunity level of the product is unknown.
- Modification of any kind to the electronics of this mobility device as manufactured by Invacare may adversely affect the EMI immunity levels.

### 3.3 Powered Wheelchair Electromagnetic Emissions

**CAUTION!****Risk of Injury or Damage**

EMC interference affecting other products may result in injury or damage.

**To avoid impacting the operation and function of other products:**

- Products not specified by Invacare that may be used on or near the mobility device may be impacted by emissions from this product if they have a sensitivity level that is lower than the recognized standard and provided by this mobility device. Refer to the manufacturer specifications for any electronic device BEFORE use near this product to determine its level of immunity and potential risk.

## 4 Components

### 4.1 Component Overview

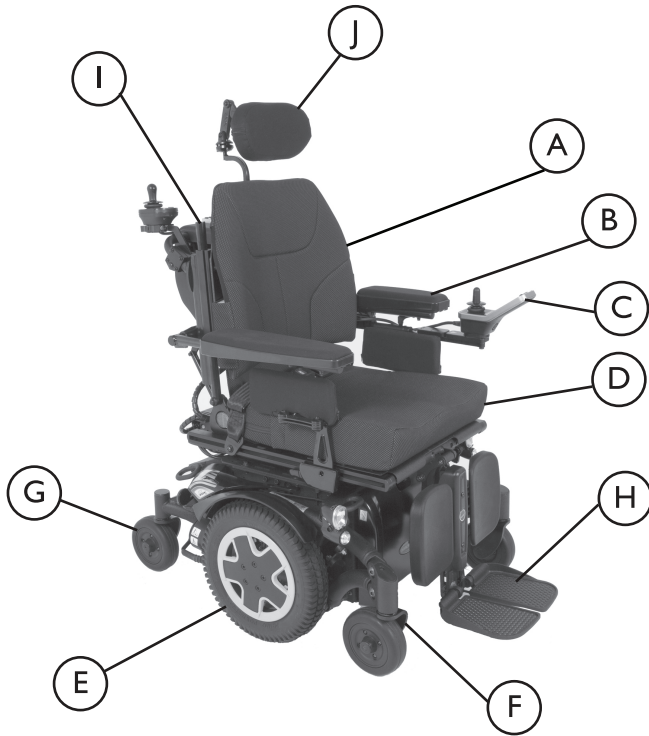

Fig. 4-1

ITEM	DESCRIPTION
A	Back Cushion
B	Armrest
C	Remote (Joystick)
D	Seat Cushion
E	Drive Wheel
F	Fork
G	Caster
H	Front Rigging
I	Back Cane
J	Headrest

### 4.2 Remotes

Remotes include joysticks and other devices used to drive the power wheelchair, operate the powered seating system or operate other functions. Your power wheelchair may be equipped with one of several different remotes. For information on the different functions and how to operate a particular remote, refer to its corresponding user manual (enclosed).

### 4.3 The Powered Seating System

The powered seating system is operated from the remote. Refer to the remote manual for more information.

The powered seating system may include the following functions, depending on the modules installed:

- Tilt
- Recline
- Tilt with Elevating Seat
- Tilt and Recline with Elevating Seat
- Power Elevating Center Mount Legrest
- Power Elevating Dual Legrests



Information regarding operation of the elevating seat at temperatures of less than 0 °C

- Invacare mobility devices are equipped with safety mechanisms that prevent capacity overload of the electronic components. At operating temperatures below freezing point this can, in particular, lead to the elevating seat actuator being shut down after approximately 1 second operating time.
- The elevating seat can be raised or lowered gradually by repeatedly operating the joystick. In many cases this generates sufficient heat for the actuator to operate as normal.



## Drive Slow-Down

The drive slow-down reacts in different ways, depending on the mobility device's configuration.

- The elevating seat is equipped with sensors which reduce the mobility device's speed as soon as the elevating seat is raised above a certain point. The wheelchair is also equipped with a sensor that reduces speed when the seat is tilted or reclined past a specific angle.
- The drive slow-down takes place to guarantee the tipping stability of the mobility device and to avoid personal risk and damage to the mobility device.
- To reapply normal speed, lower the elevating seat down or return the seat back to an upright position until the drive slow-down switches off.



### **CAUTION!**

#### **Risk of Injury or Damage**

There is a risk of tipping if the drive slow-down sensors fail when the elevating seat is raised.

- If you find that the drive slow-down function is not working when the elevating seat is raised, do not drive with the elevating seat raised and immediately contact an Invacare provider.

## 4.4 Labels on the Product



### **DANGER!**

#### **Risk of Injury, Damage or Death**

Missing or damaged labels may contribute to injury, damage or death.

– Ensure ALL labels are present and legible.



Labels are subject to change without notice.

### All Wheelchairs

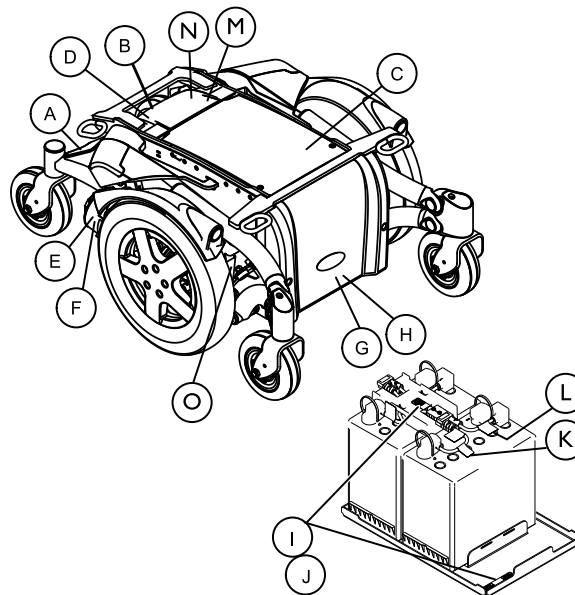









Fig. 4-2

ITEM	PART NUMBER	DESCRIPTION
A	1190611	 <p>Fig. 4-3 Serial Number Label</p>



B	1167422	 <p data-bbox="459 239 702 262"><i>Fig. 4-4 *Controller Label</i></p>
C	1035900	 <p data-bbox="459 349 702 371"><i>Fig. 4-5 Transportation Label</i></p>
D	1111028	 <p data-bbox="459 493 702 538"><i>Fig. 4-6 Weight Capacity Label—Non-Elevate</i></p>
	1111026	 <p data-bbox="459 665 702 710"><i>Fig. 4-7 Weight Capacity Label—Elevate</i></p>

E	1167424	 <p data-bbox="1171 225 1493 269"><i>Fig. 4-8 Replacing Motor/Gearbox Label</i></p>
F	1104802	 <p data-bbox="1209 426 1452 449"><i>Fig. 4-9 Push/Drive Label</i></p>

<b>G</b>	1114826
----------	---------

**⚠ WARNING**

**Wiring Diagram Install/Remove for 22NF Batteries  
DO NOT REMOVE THIS LABEL**

The **POSITIVE (+) RED Battery Cable MUST** connect to the **POSITIVE (+) Battery Terminal(s)/Post(s)**.

The **NEGATIVE (-) BLACK Battery Cable MUST** connect to the **NEGATIVE (-) Battery Terminal(s)/Post(s)**.

—**DO NOT** allow Battery Cables to contact the opposite Battery Terminal(s)/Post(s). —Install protective caps on positive and negative battery terminals. —Replace cable(s) immediately if cable(s) insulation becomes damaged. —Failure to observe these warnings may cause an electrical short resulting in death, serious injury and/or damage to the electrical system. —See User Manual.

**DO NOT** remove fuse or mounting hardware from **POSITIVE (+) RED battery cable mounting screw.**

Disconnect/Connect from/to Controller Wiring Harness

**22NF**

1114826-C-01

*Fig. 4-10 \*\*22NF Battery Wiring Diagram Label*

<b>H</b>	1114847
----------	---------

**⚠ WARNING**

**22NF batteries with terminal configuration (positive on the left and negative on the right) as shown MUST be used. 22NF batteries that have the reverse terminal configuration MUST NOT be used. Terminals MUST have a cross hole located as shown for proper battery connection. See the user manual. These recommendations MUST be followed otherwise injury and/or damage may occur.**

**Positive Terminal**

**Negative Terminal**

← **Cross Hole**

**USE this Battery terminal configuration**

**Negative Terminal**

**Positive Terminal**

**DO NOT use this Battery terminal configuration**

1114847-C-00

*Fig. 4-11 \*\*22NF Battery Wiring Diagram Label*

<b>G</b>	1114825
----------	---------

**⚠ WARNING**

**Wiring Diagram Install/Remove for GP24 Batteries  
DO NOT REMOVE THIS LABEL**

The **POSITIVE (+) RED Battery Cable MUST** connect to the **POSITIVE (+) Battery Terminal(s)/Post(s)**.

The **NEGATIVE (-) BLACK Battery Cable MUST** connect to the **NEGATIVE (-) Battery Terminal(s)/Post(s)**.

—**DO NOT** allow Battery Cables to contact the opposite Battery Terminal(s)/Post(s). —Install protective caps on positive and negative battery terminals. —Replace cable(s) immediately if cable(s) insulation becomes damaged. —Failure to observe these warnings may cause an electrical short resulting in death, serious injury and/or damage to the electrical system. —See User Manual.

**DO NOT** remove fuse or mounting hardware from **POSITIVE (+) RED** battery cable mounting screw.

Disconnect/Connect from/to Controller Wiring Harness

**GP24** 1114825-D-03

*Fig. 4-12 \*\*GP24 Battery Wiring Diagram Label*

<b>H</b>	1114848
----------	---------

**⚠ WARNING**

**GP24 batteries with terminal configuration (negative on the left and positive on the right) as shown MUST be used. GP24 batteries that have the reverse terminal configuration MUST NOT be used. Terminals MUST have a cross hole located as shown for proper battery connection. See the user manual. These recommendations MUST be followed otherwise injury and/or damage may occur.**

**Cross Hole**

**USE this Battery terminal configuration**

**DO NOT use this Battery terminal configuration**

1114848-C-00

*Fig. 4-13 \*\*GP24 Battery Wiring Diagram Label*





I	1118356	 <p>Use 22NF Batteries Only. See Owner's Manual.</p> <p>Utiliser les batteries 22NF seulement. Se référer au manuel de l'utilisateur.</p>
J	1118355	 <p>Use GP24 Batteries Only. See Owner's Manual.</p> <p>Utiliser les batteries GP24 seulement. Se référer au manuel de l'utilisateur.</p>
K	1098362	 <p>POSITIVE (+) RED WIRE. DO NOT REMOVE THIS LABEL.</p> <p>POSITIVE (+) RED WIRE. NE PAS ENLEVER CE ÉTIQUETTE.</p>
L	1098363	 <p>NEGATIVE (-) BLACK WIRE. DO NOT REMOVE THIS LABEL.</p> <p>NEGATIVE (-) BLACK WIRE. NE PAS ENLEVER CE ÉTIQUETTE.</p>
M	1195676	 <p>Before using this product, read and understand the User Manual. The user manual provides proper operation and safe practice. Documentation can be obtained at: Avant d'utiliser ce produit, assurez-vous de lire et de comprendre le manuel de l'utilisateur. Il contient des renseignements importants et des conseils sur le fonctionnement sûr et adéquat du produit. La documentation peut être obtenue auprès de:</p> <p>• <a href="http://www.invacare.com">www.invacare.com</a> • Tel: (800) 729-4505 • One Invacare Way, Troy, NY USA 12187          • <a href="http://www.invacare.ca">www.invacare.ca</a> • Tel: (800) 668-5324 • 515 Marlborough Blvd E Unit 8, Mississauga Ontario, L4Z 6G4 Canada          • <a href="http://www.invacare.com.au">www.invacare.com.au</a> • Tel: (0800) 660 665 • 1 Luton Place, North Rocks NSW 1515 Australia          • <a href="http://www.invacare.co.nz">www.invacare.co.nz</a> • Tel: (800) 668 322 • 4 Westfield Place, Mt Wellington 1060 New Zealand</p>

Fig. 4-14 \*\*\* 22NF Battery Label

Fig. 4-15 \*\*\* GP24 Battery Label

Fig. 4-16 Positive Battery Wire Label

Fig. 4-17 Negative Battery Wire Label

Fig. 4-18 Contact/Consult Manual Label

N	1195057	 <p>This product may be covered by one or more U.S. patents or pending patent applications. See <a href="http://www.invacarepatents.com">www.invacarepatents.com</a></p>
O	1195679	 <p><b>WARNING</b>          Risk of Injury, Damage or Death. Loss of traction or stability on rough or unstable terrain may cause injury, damage or death. Use care when operating the wheelchair on rough or unstable terrain. This would include but is not limited to areas of rock, mulch, mud, uneven pavement, roots and similar conditions. Be aware of your surroundings and conditions that might affect the ability to operate the wheelchair. 1195679-9</p>

Fig. 4-19 Patent Label

Fig. 4-20 Driving Surfaces Label

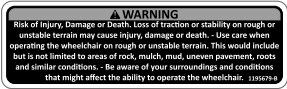

\* Label located under the controller.

\*\* Labels located under front shroud. Only one set of labels will appear depending on chair model.

\*\*\* Only one of the battery labels (22NF or GP24) will appear depending on chair model.

### Wheelchairs with the Transport Ready Option

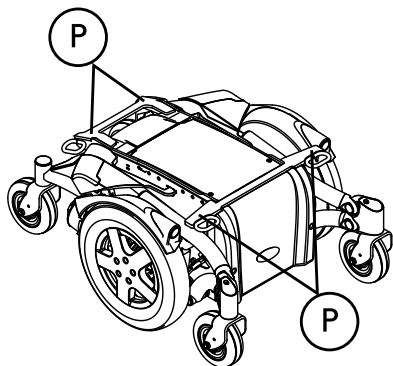



Fig. 4-21 All Wheelchairs with the Transport Ready Option

ITEM	PART NUMBER	DESCRIPTION
P	1554407	 <p data-bbox="1137 333 1473 404">ISO 7176-19 Fig. 4-23 ISO 7176-19 Compliance Label</p>

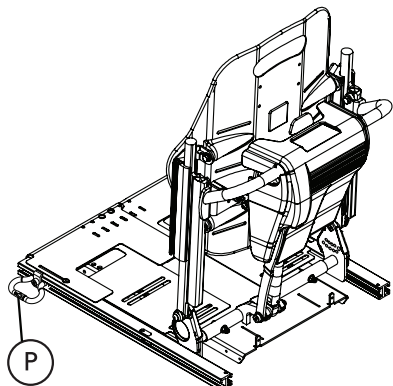
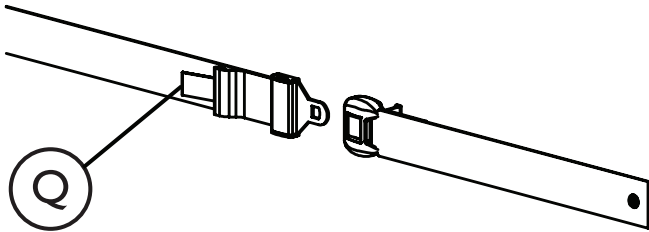
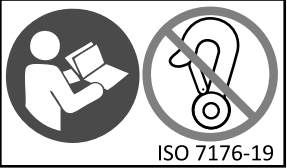

Fig. 4-22 Wheelchairs with Elevate and the Transport Ready Option

On ALL Positioning Belts



ITEM	PART NUMBER	DESCRIPTION
Q	1195716	 <p>ISO 7176-19</p> <p><i>Fig. 4-24 ISO 7176-19 Non-Compliance Label</i></p>

Wheelchairs with Transport Brackets (TRBKTS)

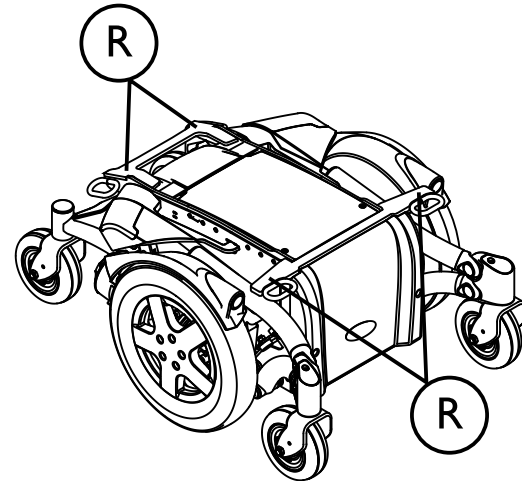

*Fig. 4-25*

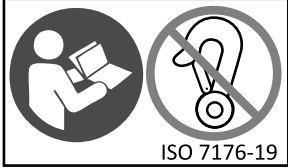
ITEM	PART NUMBER	DESCRIPTION
R	1553016	 <p>ISO 7176-19</p> <p><i>Fig. 4-26 ISO 7176-19 Non-Compliance Label</i></p>

## 5 Setup

### 5.1 Setup/Delivery Inspection



Setup/delivery inspection should be performed by provider at time of delivery/set up.

Initial adjustments should be made to suit your personal body structure needs and preference. Thereafter weekly, monthly and periodic inspections should be performed by user/attendant between the six month service inspections. Refer to 9 *Maintenance*, page 65.

- Check all parts for shipping damage. In case of damage, DO NOT use.
- Ensure wheelchair rolls straight (no excessive drag or pull to one side).
- Ensure clothing guards are secure.
- Ensure arms are secure but easy to release and adjustment levers engage properly.
- Ensure adjustable height arms operate and lock securely.
- Ensure axle nut or bolt and wheel mounting nuts are secure on drive wheels.
- Ensure caster/anti-tipper wheels are free of debris, and all mounting hardware is secure and not damaged/missing.
- Check that cables are routed and secured properly to ensure that cables do NOT become entangled and damaged during normal operation of seating system.
- Ensure proper operation of powered functions (Example: drive, seating and legrests).

### 5.2 Adjusting Joystick Mount

#### Adjusting the Height of the Joystick Mount

You can adjust the height of the nucleus midline holder in two ways:

- Adjust it together with the armrest height. Refer to the user manual for the seating system.
- Adjust the height of the nucleus midline holder only. Refer to section below.



- 3/16" (4.8 mm) Allen key

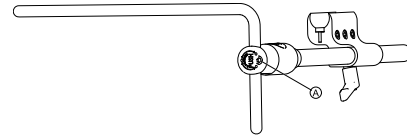

Fig. 5-1

1. Loosen screw A.
2. Adjust nucleus to desired height.
3. Tighten screw.

#### Adjusting the Depth of the Joystick Mount

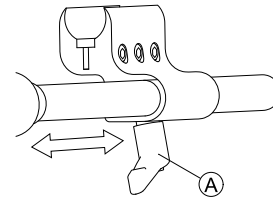

Fig. 5-2

1. Loosen lever (A).
2. Shift midline holder to desired position.
3. Tighten lever.

### Adjusting Joystick on the Joystick Mount

---



- 5/32" (4 mm) Allen key
- 

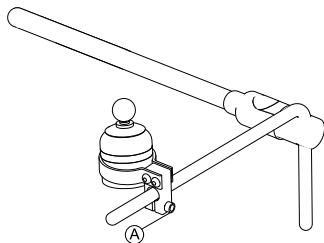

Fig. 5-3

1. Loosen screw (A).
2. Position joystick on holder.
3. Tighten screw.



With one turn of the screw, the joystick can be rotated in a complete 360 degree radius. There is a slot on the side that will allow you to angle the joystick at 90 degrees.



## 6 Usage

### 6.1 Folding the Joystick Mount Up and Down

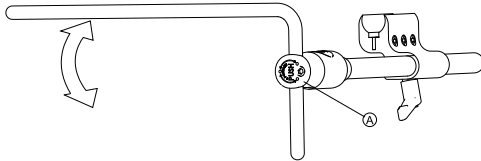



Fig. 6-1

1. Push button **A** and fold up.
2. Push button **A** and fold down.

### 6.2 Pushing the Mobility Device in Freewheel Mode

The motors of the mobility device are equipped with motor locks, which prevent the mobility device from rolling when the remote is switched off. When pushing the mobility device manually while freewheeling, the motor locks must be disengaged.

-  Pushing the mobility device by hand may require more physical force than expected (more than 100 N). The necessary force nevertheless complies with the requirements of ISO 7176-14.
-  The intended use of the freewheel mode is to maneuver the mobility device over short distances. The push handles or push bars support this function, but be aware that there might be some interference between the feet of the assistant and the rear part of the mobility device.

### 6.2.1 Disengaging/Engaging the Motor Lock Levers

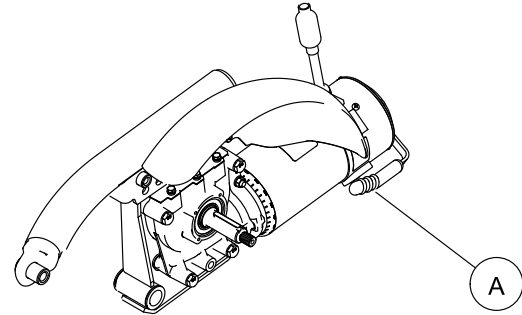

Fig. 6-2



#### **WARNING!**

#### **Risk of Injury or Damage**

Misuse of motor locks may result in injury or damage.

- DO NOT engage or disengage motor locks until the power is in the off position.



Motor lock **A** disengagement/engagement allows free-wheeling or joystick controlled operation. Free-wheeling allows an assistant to maneuver the wheelchair without power.

Motor lock levers are located between the rear caster assembly and drive wheel on both sides of the wheelchair.

1. Turn off the wheelchair power.
2. Perform one of the following as if viewing the motors from behind the wheelchair (Detail "A"):
  - Disengage (PUSH) - Move the motor lock levers UP to disengage the motors and push the wheelchair.
  - Engage (DRIVE) - Move the motor lock levers DOWN to engage the motors and drive the wheelchair.

### 6.3 Disengaging/Engaging the Wheel locks



**WARNING!**  
**Risk of Injury or Damage**

Misuse of wheel locks may result in injury or damage.

- DO NOT attempt to stop a moving wheelchair with the wheel locks. Wheel locks are not brakes.
- DO NOT use the wheel locks (if equipped) when the wheelchair power is on. Invacare recommends the use of wheel locks.



Use the wheel locks to hold the wheelchair in place whenever the clutches are disengaged.

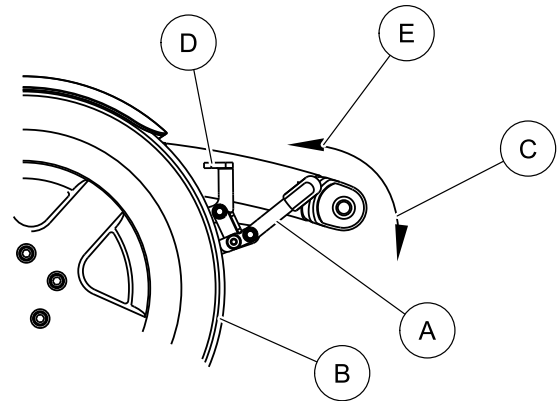

Fig. 6-3

#### 6.3.1 Engaging

1. Push handle (A) forward (C) away from tire (B) to engage wheel lock (D).
2. Repeat STEP 1 for opposite wheel.

#### 6.3.2 Disengaging

1. Pull handle (A) back (E) toward tire (B) to disengage wheel lock (D).
2. Repeat STEP 1 for opposite wheel.

---

## 7 Controls System

---

### 7.1 Controls Protection System

The wheelchair controls system is equipped with an overload protection.

If the drive is severely overloaded over a long period of time (for example, when driving up a steep hill) and especially when the ambient temperature is high, the controls system could overheat. In this case, the wheelchair performance is gradually reduced until it stops. The status display shows a corresponding error code (refer to the user manual for your remote). By switching the power supply off and back on again, the error code is cleared and the controls system is switched back on. It can however take up to five minutes until the controls system has cooled down enough for the drive to restore full performance again.

If the drive is stalled by an insurmountable obstacle, for example, a curb or similar which is too high, and the driver attempts driving for more than 20 seconds against this obstacle, the controls system automatically switches off to prevent the motors from being damaged. The status display shows a corresponding error code (refer to the user manual of your remote). By switching off and back on again, the error code is cleared and the controls system is switched back on.



A defective main fuse may be replaced only after checking the entire controls system. A specialized Invacare provider must perform the replacement. You can find information on the fuse type in *12 Technical Data, page 77*.

### 7.2 Batteries

Power is supplied by two 12 V batteries. The batteries are maintenance-free and only need regular charging.

In the following, you find information on how to charge, handle, transport, store, maintain, and use batteries.

#### 7.2.1 General Information on Charging

New batteries should always be fully charged once before their first use. New batteries will be at their full capacity after having run through approximately 10 - 20 charging cycles (break-in period). This break-in period is necessary to fully activate the battery for maximum performance and longevity. Thus, range and running time of your mobility device could initially increase with use.

Gel/AGM lead acid batteries do not have a memory effect like NiCd batteries.

#### 7.2.2 General Instructions on Charging

Follow the instructions listed below to ensure safe use and longevity of the batteries:

- Charge 18 hours prior to initial usage.
- We recommend charging the batteries daily after every discharge even after partly discharge, as well as each night over night. Depending on the level of discharge, it can take up to 12 hours until the batteries are fully charged again.
- When the battery indicator reaches the red LED range, charge the batteries for at least 16 hours, even if the display reads that the charge is complete.
- Try to provide a 24 hour charge once a week to make sure that both batteries are fully charged.

- Do not cycle your batteries at a low state of charge without regularly recharging them fully.
- Do not charge your batteries under extreme temperatures. High temperatures above 86 °F (30 °C) are not recommended for charging as well as low temperatures below 50 °F (10 °C).
- Use only charging devices in Class 2. This class of chargers may be left unattended during charging. All charging devices which are supplied by Invacare comply with these requirements.
- You cannot overcharge the batteries when using the charger supplied with your mobility device, or a charger that has been approved by Invacare.
- Protect your charger from sources of heat such as heaters and direct sunlight. If the battery charger overheats, charging current will be reduced and the charging process delayed.

### 7.2.3 How to Charge the Batteries

Refer to the user manuals for your remote and battery charger for the position of the charging socket and further information about charging the batteries.



#### **WARNING!**

##### **Risk of Injury or Damage**

Using the wrong battery charger may cause explosion and destruction of batteries. To avoid injury or damage:

- Only use the battery charger supplied with your mobility device, or a charger that has been approved by Invacare.



#### **WARNING!**

##### **Risk of Injury, Damage or Death**

Improper charging may cause injury or damage.

- Charge battery in a cool, dry and well-ventilated area.
- DO NOT attempt to charge the battery by attaching cables directly to the battery terminals.
- DO NOT attempt to charge the battery and operate the wheelchair at the same time.
- DO NOT attempt to charge the battery when the wheelchair has been exposed to any type of moisture.
- DO NOT sit in the wheelchair while charging the battery.
- DO NOT leave the charger unattended when the breaker has tripped. Unplug and discontinue use immediately. Contact a qualified service technician or Invacare for service.



#### **WARNING!**

##### **Risk of Injury or Damage**

Explosive gases can be generated while charging. To avoid flammable gas buildup and injury or damage due to explosion:

- During charging, keep the wheelchair and battery charger away from sources of ignition, such as flames and sparks.
- Charge the wheelchair in a space at least twice the volume of the wheelchair.

**WARNING!****Risk of short circuit and electric shock if the battery charger has been damaged**

- Do not use the battery charger if it has been dropped or damaged.

**WARNING!****Risk of Injury, Damage or Death**

Improper routing of cord(s) may cause tripping, entanglement or strangulation hazard that may result in injury, damage or death.

- Ensure all cord(s) are routed and positioned properly while charging.
- Avoid positioning cord(s) across areas of high foot traffic (i.e. aisles, doorways, hallways, etc.) while charging.
- Close supervision and attention is needed when operating the wheelchair near children, pets or people with physical/mental disabilities.

## 1. Perform one of the following

- Charging NEW batteries—Ensure the mobility device power is ON.



The wheelchair power must be on to ensure that accurate battery charge levels display on the remote. New batteries must be charged fully. This includes on initial delivery and after battery replacement. The Battery Synchronization Procedure **MUST** be performed within 24 hours of powering on the wheelchair. The Battery Synchronization Procedure can be found in the LiNX service manual and must be performed by a provider or qualified technician.

- Charging existing batteries—Switch off the mobility device.

## 2. Connect the battery charger to the charger socket.



The charger connector pins are identified in the following ways:

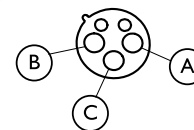

Fig. 7-1

- Pin 1 **A** — Battery Plus (+)
- Pin 2 **B** — Battery (-)
- Pin 3 **C** — Inhibit

## 3. Connect the battery charger to the power supply.

### 7.2.4 How to Disconnect the Mobility Device After Charging

1. Once charging is complete, disconnect the battery charger from the power supply.
2. Disconnect the plug from the remote.

### 7.2.5 Storage and Maintenance

Follow the instructions listed below to ensure safe use and longevity of the batteries:

- Always store the batteries fully charged.
- Do not leave the batteries in a low state of charge for an extended length of time. Charge a discharged battery as soon as possible.
- In case your mobility device is not used for a longer period of time (that is more than two weeks), the batteries must be charged at least once a month to maintain a full charge and always be charged before use.
- Avoid hot and cold extremes when storing. We recommend to store batteries at a temperature of 59 °F (15 °C).
- Gel and AGM batteries are maintenance-free. Any performance issues should be handled by a properly trained mobility device technician.

### 7.2.6 Using the Proper Batteries



#### **WARNING!**

#### **Risk of Injury or Damage**

Improper configuration of battery terminals may cause injury or damage.

- Batteries with terminal configuration as shown **MUST** be used.
- Terminals **MUST** have a cross hole in them as shown.
- The **POSITIVE (+) RED** battery cable **MUST** connect to the **POSITIVE (+)** battery terminals/posts.
- The **NEGATIVE (-) BLACK** battery cable **MUST** connect to the **NEGATIVE (-)** battery terminals/posts.
- **DO NOT** allow any of your tools and/or battery cables to contact both battery terminals at the same time.



#### **CAUTION!**

#### **Risk of Damage**

Use of wrong battery type or size may cause damage.

- **DO NOT** force a battery into place.
- Batteries with molded straps or flanges that interfere with proper battery placement should not be used.
- Use batteries listed in this manual for proper replacement.



Failure to use the correct battery size and/or voltage may cause damage to your wheelchair and give you unsatisfactory performance. The warranty and performance specifications contained in this manual are based on the use of deep cycle gel cell batteries. Invacare strongly recommends their use as the power source for this unit.

Carefully read battery/battery charger information prior to installing, servicing or operating your wheelchair.

1. Position battery on ground/flat surface as shown below.
2. Visually inspect the battery to ensure proper polarity:

#### FOR WHEELCHAIRS USING 22NF BATTERIES

Batteries with terminal configuration (POSITIVE Ⓐ on the left and NEGATIVE Ⓑ on the right) as shown below MUST be used. Batteries that have the reverse terminal configuration MUST not be used - otherwise injury and damage may occur.

Terminals must be have a cross hole Ⓒ in them as shown below.

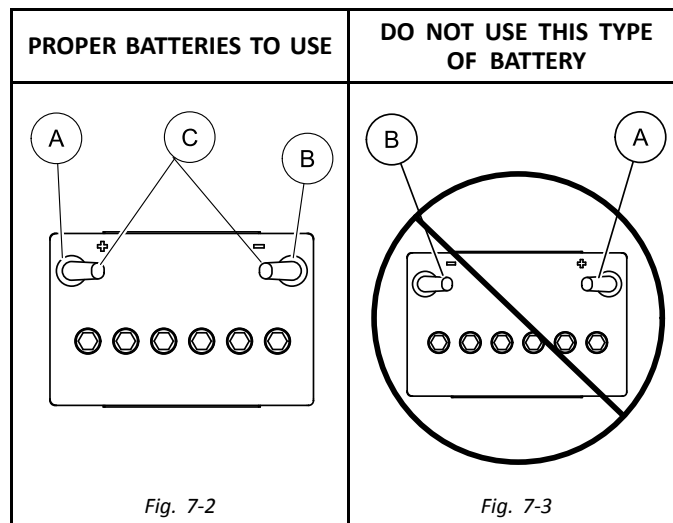

#### FOR WHEELCHAIRS USING GP24 BATTERIES

Batteries with terminal configuration (POSITIVE Ⓐ on the right and NEGATIVE Ⓑ on the left) as shown below MUST be used. Batteries that have the reverse terminal configuration MUST not be used - otherwise injury and damage may occur.

Terminals must be have a cross hole Ⓒ in them as shown below.

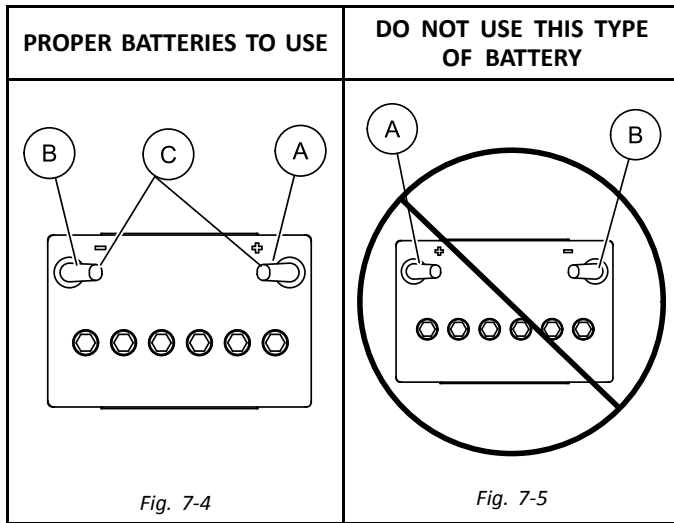

### 7.2.7 Instructions on Using the Batteries



#### CAUTION!

#### Risk of damaging the batteries.

– Avoid ultra-deep discharges and never drain your batteries completely.

- Pay attention to the Battery Charge Indicator! Charge the batteries when the Battery Charge Indicator shows that battery charge is low.

How fast the batteries discharge depends on many circumstances, such as ambient temperature, condition of the surface of the road, tire pressure, weight of the driver, way of driving and utilisation of lighting, if equipped.

- Try to charge the batteries always before you reach the red LED range.  
The last 3 LED (one red and two orange) mean a remaining capacity of about 15%.
- Driving with flashing red LED's means an extreme stress for the battery and should be avoided under normal circumstances.
- When only one red LED is flashing, the Battery Safe feature is enabled. From this time, speed and acceleration is reduced drastically. It will allow you to move the mobility device slowly out of a dangerous situation before the electronic finally cuts off. This is deep discharging and should be avoided.
- Be aware that for temperatures below 68 °F (20 °C), the nominal battery capacity starts to decline. For example, at 14 °F (-10 °C) the capacity is reduced to about 50% of the nominal battery capacity.
- To avoid damaging the batteries, never allow them to be fully discharged. Do not drive on heavily discharged batteries if it is not absolutely necessary, as this will strain the batteries unduly and shorten their life expectancy.
- The earlier you recharge the batteries, the longer they live.



- The depth of discharge affects the cycle life. The harder a battery has to work, the shorter is its life expectancy. Examples:
    - One deep discharge stresses the same as 6 normal cycles (green /orange display off).
    - The battery life is about 300 cycles at 80% discharge (first 7 LED off), or about 3000 cycles at 10% discharge (one LED off).
-  The number of LED can vary depending on the remote type.
- Under normal operation, once a month the battery should be discharged until all green and orange LED are off. This should be done within one day. A 16 hour charge afterwards is necessary as reconditioning.

### 7.2.8 Transporting Batteries

The batteries supplied with your mobility device are not hazardous goods. This classification is based on the German GGVS Hazardous Goods Road Transport Ordinances, and the IATA/DGR Hazardous Goods Rail Transport / Air Transport Ordinances. Batteries may be transported without restrictions, whether by road, rail or by air. Individual transport companies have, however, guidelines which can possibly restrict or forbid certain transport procedures. Please ask the transport company regarding each individual case.

### 7.2.9 General Instructions on Handling the Batteries

- Never mix and match different battery manufacturers or technologies, or use batteries that do not have similar date codes.
- Never mix gel with AGM batteries.

- The batteries reach their end of life when the drive range is significantly smaller than usual. Contact your provider or service technician for details.
- Always have your batteries installed by a properly trained mobility device technician or a person with adequate knowledge. They have the necessary training and tools to do the job safely and correctly.

### 7.2.10 How to Handle Damaged Batteries Correctly



#### **CAUTION!**

**Corrosion and burns from acid leakage if batteries are damaged**

- Remove clothes that have been soiled by acid immediately.

#### **After contact with skin:**

- Immediately wash affected area with lots of water.

#### **After contact with eyes:**

- Immediately rinse eyes under running water for several minutes; consult a physician.

- Always wear safety goggles and appropriate safety clothing when handling damaged batteries.
- Place damaged batteries in an acid-resistant receptacle immediately after removing them.
- Only ever transport damaged batteries in an appropriate acid-resistant receptacle.
- Wash all objects that have come into contact with acid with lots of water.

## Disposing of dead or damaged batteries correctly

Dead or damaged batteries can be given back to your provider or directly to Invacare.

### 7.2.11 General Information on Battery Installation



#### **WARNING!**

##### **Risk of Injury or Damage**

Improper installation of the battery can result in injury or damage.

- Batteries can weigh up to 52 lbs (23.6 kg).  
ALWAYS use a battery lifting strap when lifting the battery. It is the most reliable method of carrying a battery and preventing serious injury.



#### **WARNING!**

##### **Risk of Injury or Damage**

Improper lifting technique may cause injury or damage.

- Use proper lifting techniques, assistance and gear such as straps when available when lifting heavy loads.



#### **WARNING!**

##### **Risk of Injury**

Exposure to battery acid may result in injury.

- The use of rubber gloves is recommended when working with batteries.
- DO NOT allow the liquid in the battery to come in contact with skin, clothes or other possessions. It is a form of acid and harmful or damaging burns may result. Should the liquid touch your skin, wash the area IMMEDIATELY and thoroughly with cool water. In serious cases or if eye contact is made, seek medical attention IMMEDIATELY.
- DO NOT install/reinstall a battery with a cracked or otherwise damaged case.



Invacare strongly recommends battery installation and replacement be performed by a qualified technician.

Read the installation instructions noted on the battery and in the manual.

Ensure there is no battery acid in the bottom or around the battery box or on the sides of the battery(ies). Neutralize battery acid with baking soda if found.

Clean battery tray and batteries prior to installation.

Use battery lifting strap when available.

Keep batteries in an upright position and avoid tipping.

Use only deep cycle gel cell battery.

Use box wrench when tightening clamps. Do Not wiggle the battery terminals/posts when tightening.

### 7.2.12 Removing the Batteries from the Wheelchair



#### **CAUTION!**

#### **Risk of Damage**

Cleaning or maintenance may cause damage to carpeting or flooring.

- Place the wheelchair in a well ventilated area where cleaning or maintenance can be performed without risk of damage to carpeting or flooring.



22NF Batteries shown

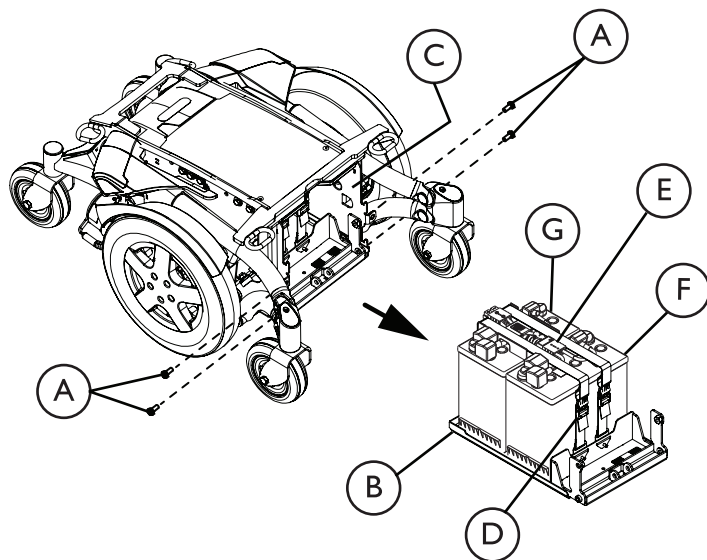

Fig. 7-6

1. Place the wheelchair in a well ventilated area.
2. Verify the remote On/Off switch is in the Off position and disconnect by unplugging the cable from the remote.  
Remove the rear shroud, front shroud and battery retention bracket. Refer to 9.6 *Removing/Installing the Shrouds*, page 70.
3. Disconnect the controller from the batteries at the rear of the wheelchair.
4. Remove the four mounting screws (A) securing the battery tray (B) to the frame (C).
5. Slide battery tray with batteries out.

6. Disconnect the battery straps (D).



Battery connection (E) located on top.

7. Disconnect batteries.
8. Remove the front (F) battery.
9. Slide the rear battery (G) forward and remove it from the tray.

### 7.2.13 Installing Batteries into the Wheelchair



#### **WARNING!**

#### **Risk of Serious Injury**

Improperly installed battery tray can cause instability resulting in serious injury.

- Ensure batteries and battery tray are installed properly to maintain stability.

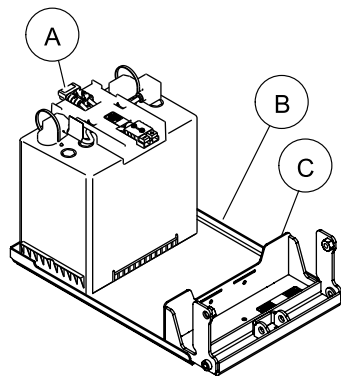

Fig. 7-7

1. Position the battery with battery connector bracket (A) against the back edge of the battery tray (B) in the orientation as shown.

**i** Batteries **MUST** be installed in the orientation shown so that the wiring harnesses can be connected together.

2. Position the remaining battery between the battery on the tray and battery stop (C).
3. Connect batteries together (D).
4. Connect battery straps (E).
5. Slide the battery tray into the wheelchair
6. Install the rear shroud, front shroud and battery retention bracket. Refer to *9.6 Removing/Installing the Shrouds*, page 70.
7. If Installing NEW batteries—The Battery Synchronization Procedure **MUST** be performed within 24 hours of powering on the wheelchair. Otherwise the battery gauge will not display accurate battery charge levels. The Battery Synchronization Procedure can be found in the LiNX service manual and must be performed by a provider or qualified technician.

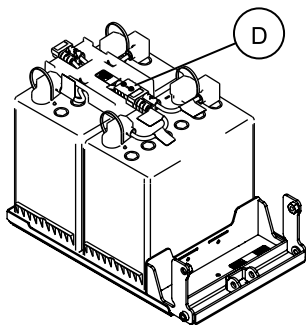

Fig. 7-8

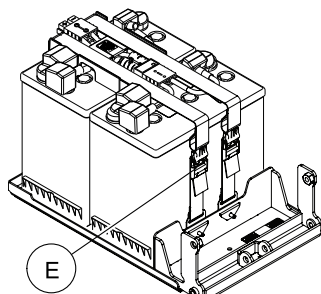

Fig. 7-9

**i** Positioning of the batteries into the battery tray is completed with battery tray positioned in wheelchair and partially pulled out. Illustrations are shown without the wheelchair for clarification purposes only.

### 7.2.14 Replacing Batteries and/or Battery Cables



Have the following tools available: 7/16 inch (6 pt) Box Wrench and Diagonal Cutters.

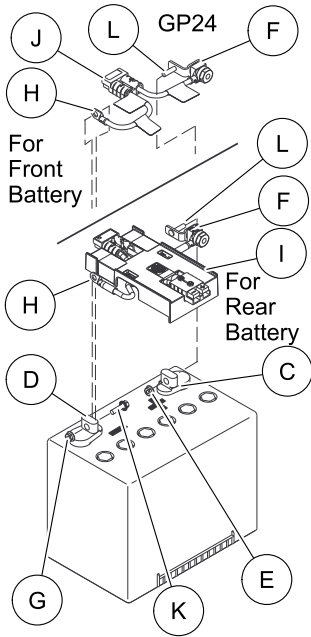

Fig. 7-10

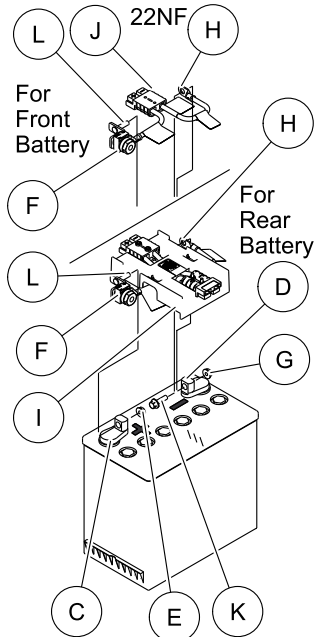

Fig. 7-11

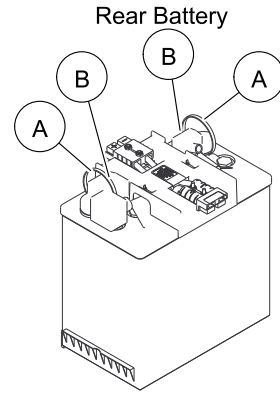

Fig. 7-12

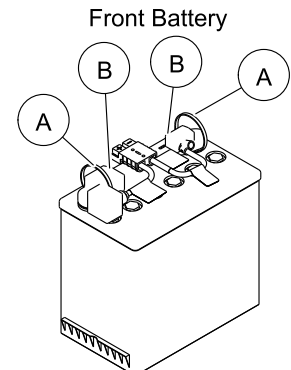

Fig. 7-13

**WARNING!****Risk of Death or Serious Injury**

Failure to observe these warnings can cause an electrical short resulting in death, serious injury, or damage to the electrical system.

- The POSITIVE (+) RED battery cable MUST connect to the POSITIVE (+) battery terminal(s)/post(s).
- The NEGATIVE (-) BLACK battery cable MUST connect to the NEGATIVE (-) battery terminal(s)/post(s).
- NEVER allow any of your tools and/or battery cable(s) to contact BOTH battery post(s) at the same time. An electrical short may occur and serious injury or damage may occur.
- Install protective caps on positive and negative battery terminals.
- Replace cable(s) immediately if cable(s) insulation becomes damaged.
- DO NOT remove fuse or mounting hardware from POSITIVE (+) red battery cable mounting screw.

1. Remove the batteries from the wheelchair. Refer to 7.2.12 *Removing the Batteries from the Wheelchair*, page 51.
2. Cut the tie-wraps (A) that secure the battery terminal covers (B) to the battery terminals.
3. Slide the RED battery terminal cover back on the red battery cable to expose the POSITIVE battery terminal (C).
4. Slide the BLACK battery terminal cover back on the Black battery cable to expose NEGATIVE battery terminal (D).

5. Remove the locknut (E) that secures the bracket (F) of the POSITIVE battery cable to the POSITIVE (+) battery post of the battery.
6. Remove the locknut (G) that secures the NEGATIVE battery cable (H) to the NEGATIVE (-) battery post of the battery.
7. Discard the existing battery per local laws and regulations. Refer to 10.2 *Disposal*, page 73.
8. Position battery connector bracket (I) or wiring harness (J) onto the new 22NF battery or GP24 battery as shown.
9. Secure the NEGATIVE battery cable (H) to the NEGATIVE (-) battery post with existing mounting screw (K) and locknut (G).
10. Secure the bracket (F) of the POSITIVE battery cable to the POSITIVE (+) battery post with existing mounting screw (L) and locknut (E).
11. Position each battery terminal cover over top of each battery terminal.
12. Secure battery terminal covers in place with one tie-wrap.
13. Install batteries into wheelchair. Refer to 7.2.13 *Installing Batteries into the Wheelchair*, page 52.

## 7.2.15 Cleaning Battery Terminals



### **WARNING!**

#### **Risk of Injury**

Exposure to battery acid may result in injury.

- The use of rubber gloves is recommended when working with batteries.
- DO NOT allow the liquid in the battery to come in contact with skin, clothes or other possessions. It is a form of acid and harmful or damaging burns may result. Should the liquid touch your skin, wash the area IMMEDIATELY and thoroughly with cool water. In serious cases or if eye contact is made, seek medical attention IMMEDIATELY.
- DO NOT install/reinstall a battery with a cracked or otherwise damaged case.

1. Examine battery terminals for corrosion.
2. Verify the plastic caps are in place over battery cell holes.
3. Clean terminals by using a battery cleaning tool, wire brush, or medium grade sand paper.
  -  Upon completion, areas should be shiny, not dull.
4. Carefully dust off all metal particles.



## 8 Transport

### 8.1 Wheelchair Transport Brackets (TRBKTS)

As of this date, the Department of Transportation has not approved any tie-down systems for transportation of a user while in a wheelchair, in a moving vehicle of any type. It is Invacare's position that users of wheelchairs should be transferred into appropriate seating in vehicles for transportation and use be made of the restraints made available by the auto industry. Invacare cannot and does not recommend any wheelchair transportation system.

TRBKTS includes four factory-installed wheelchair transport brackets.

TRBKTS wheelchair models and configurations may not be used as a vehicle seat and are identified by the following label on the device:



Fig. 8-1



#### **WARNING!**

##### **Risk of Injury, Damage or Death**

Improper use of wheelchair transport brackets (TRBKTS) may result in injury, damage or death.

- Use these transport brackets only to secure an unoccupied wheelchair during transport.
- Ensure wheelchair is secured using proper restraint systems. Wheelchair transport brackets have not been crash-tested in accordance with ISO 7176–19.
- Only use the transport brackets for the purposes described in this manual.

### 8.2 Transport Ready Option (TRRO)

As of this date, the Department of Transportation has not approved any tie-down systems for transportation of a user while in a wheelchair, in a moving vehicle of any type. It is Invacare's position that users of wheelchairs should be transferred into appropriate seating in vehicles for transportation and use be made of the restraints made available by the auto industry. Invacare cannot and does not recommend any wheelchair transportation system.



#### **WARNING!**

##### **Risk of Injury, Damage or Death**

Failure to observe and follow transport warnings and instructions may result in injury, damage or death.

- Only use the transport brackets included with TRRO for the purposes described in this manual.

There are two Transport Ready Options available:

- TRRO — For wheelchairs without the elevate option. TRRO includes four factory-installed transport brackets.
- TRRO-E — For wheelchairs with the elevate option. TRRO-E includes six factory-installed transport brackets.

Both Transport Ready Options rely on vehicle anchored pelvic and upper-torso belts.

- The wheelchair has been tested for seating in a motor vehicle with the factory installed seating system only.
- This wheelchair has been dynamically tested in a forward-facing mode with the specified crash test dummy restrained by BOTH pelvic and upper-torso belt(s) (shoulder belts), and that BOTH pelvic and upper torso belt(s) should be used to reduce the possibility of head and chest impacts with vehicle components.
- Transport Ready Options have been crash-tested in accordance with ISO 7176–19.
- The wheelchair is identified by the following label:



ISO 7176-19

Fig. 8-2

### 8.3 Transport—General information



#### **WARNING!**

#### **Risk of Injury, Damage or Death**

Alteration or substitution may result in injury, damage or death.

- DO NOT alter or substitute product parts, components or systems.



#### **CAUTION!**

#### **Risk of Injury or Damage**

Transporting a mobility device in a vehicle with a tray installed may cause injury or damage.

- If a tray is installed, always remove it before transporting the mobility device.

## 8.4 Transferring Mobility Device to Vehicle



### WARNING!

**The mobility device is at risk of tipping over if it is transferred to a vehicle while the user is still seated in the mobility device**

- Transfer the mobility device without the user whenever possible.
- If the mobility device with the user has to be transferred to a vehicle using a ramp, ensure that the ramp does not exceed the rated slope (refer to *12 Technical Data, page 77*).
- If the mobility device has to be transferred to a vehicle using a ramp that does exceed the rated slope (refer to *12 Technical Data, page 77*), a winch must then be used. An attendant can then safely monitor and assist the transfer process.
- Alternatively, a platform lift may be used.
- Ensure that the total weight of the mobility device including the user does not exceed the maximum permitted total weight for the ramp or platform lift.
- The mobility device should always be transferred to a vehicle with the backrest in an upright position, the seat lifter lowered and the seat tilt in the upright position.



### WARNING!

**Risk of injury and damage to the mobility device**  
If the mobility device is to be transferred to a vehicle via a lift, when the remote is turned on, there is a risk that the device may act erratically and fall off the lift.

- Before transferring the mobility device via a lift, turn off the product and disconnect either the bus cable from the remote or the batteries from the system.

1. Drive or push your mobility device into the transport vehicle using a suitable ramp.

## 8.5 Use of the Mobility Device as a Seat in a Vehicle



The following section does not apply to models or configurations which may not be used as a vehicle seat. These are identified by the following label on the mobility device:

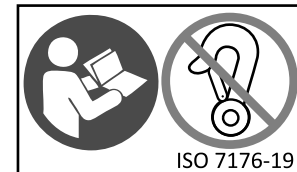

Fig. 8-3



**WARNING!**

**Risk of death or serious injury**

If a mobility device is secured using a 4-point (non-elevate systems) or 6-point (elevate systems) tie-down system available from a third party supplier and the curb weight of the mobility device exceeds the maximum weight for the system, death or serious injury to the user and potential nearby occupant.

- The actual weight of this mobility device can exceed 309 lb (140 kg). Make sure to use a 4-point or 6-point tie-down system checked and approved in accordance with ISO 10542 and certified for the actual weight of the mobility device. Consult the tie-down system manufacturer's documentation.



**WARNING!**

**Risk of injury**

Safety restraint devices must only be used when the wheelchair user's weight is 14 lb (22 kg) or more.

- When the user weight is lower than 14 lb (22 kg), do not use the wheelchair as a seat in a vehicle.



**WARNING!**

**Risk of injury**

Safety restraint devices must only be used when the wheelchair user's weight is 22 kg or more.

- When the user weight is lower than 22 kg, do not use the wheelchair as a seat in a vehicle.



**CAUTION!**

**There is a risk of injury if the mobility device is not properly secured during use as a vehicle seat.**

- If possible, the user should always leave the mobility device to use a vehicle seat and the safety belts provided with the vehicle.
- The mobility device should always be anchored facing in the transport vehicle's intended direction of travel.
- The mobility device must always be secured in accordance with the mobility device and anchoring system manufacturers' user manual.
- Always remove and secure any accessory parts fixed to the mobility device such as chin controls or tables.
- If your mobility device is equipped with an angle adjustable backrest, then it must be placed in an upright position.
- Fully lower elevated legrests, if equipped.
- Fully lower the seat lifter, if equipped.



**CAUTION!**

**Risk of injury exists if a mobility device that is not equipped with leak-proof batteries is transported in a vehicle.**

- Only ever use leak-proof batteries.

**CAUTION!**

**Risk of injury or damage to the mobility device or to the transporting vehicle, if the legrests are in a raised position while the mobility device is used as a vehicle seat.**

- Always completely lower height-adjustable legrests, if equipped.

This mobility device complies with the requirements of ISO 7176-19 and may be used as a vehicle seat in connection with an anchoring system that has been checked and approved in accordance with ISO 10542. The transporting vehicle must be professionally converted to anchor the mobility device. Contact your vehicle's manufacturer for more information.

The mobility device has undergone a crash test in which it was anchored in the transporting vehicle's direction of travel. Other configurations were not tested. The crash test dummy was secured using pelvic and upper body safety belts. Both types of safety belt should be used in order to minimize the risk of injuries to head or upper body.

It is imperative that the mobility device is inspected by an Invacare provider before being used again after being involved in a crash. Alterations to the mobility device anchoring points may not be carried out without the manufacturer's permission.

### 8.5.1 How the Mobility Device is Anchored in a Vehicle

The mobility device is equipped with tie-down points. Snap hooks or belt loops can be used for fixation. If the wheelchair can be used as a vehicle seat, these tie-down points are labelled with the symbol shown on the right.



ISO 7176-19  
Fig. 8-4

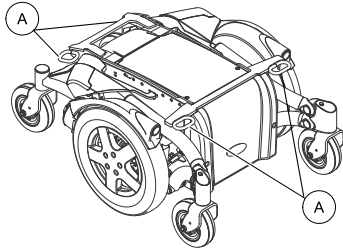

Fig. 8-5 Base Tie-Down Points—All Wheelchairs

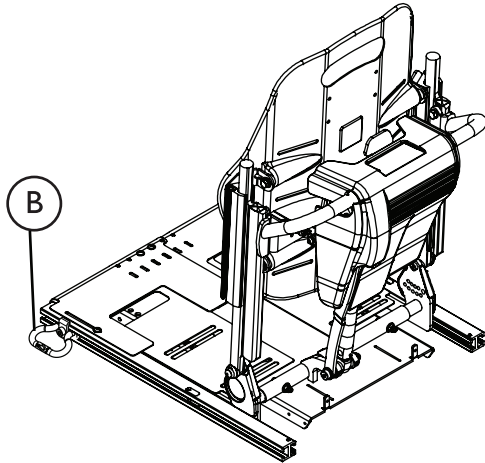

Fig. 8-6 Seat Tie-Down Points—Wheelchairs with Elevate

1. Secure the mobility device with the tie-down system belts at the following locations:
  - a. All Wheelchairs — four tie down points Ⓐ on the wheelchair base (two at the front and two at the rear).
  - b. Systems with Elevate (TRRO-E) — two additional tie down points Ⓑ on either side of the seat at the front of the seat rails.
2. Secure the mobility device by tensioning the belts in accordance with the tie-down system manufacturer's user manual.

### 8.5.2 How The User is Secured Within the Mobility Device



#### **CAUTION!**

**Risk of injury if the user is not properly secured within the mobility device**

- Even if the mobility device is equipped with a posture belt, this is no substitute for a proper safety belt which complies with ISO 10542 in the transport vehicle. Always use the safety belt installed in the transport vehicle.
- Safety belts must be in contact with the user's body. They must not be held at a distance from the user's body using parts of the mobility device such as armrests or wheels.
- Safety belts must be pulled as tightly as possible without causing the user discomfort.
- Safety belts must not be positioned while twisted.
- Ensure that the third seat belt anchorage point is not fixed directly to the vehicle floor, but to one of the vehicle uprights.

**CAUTION!**

**Risk of injury during use of the mobility device as a vehicle seat if a headrest is improperly adjusted or not installed**

This can cause the neck to be hyperextended during collisions.

- A headrest must be installed. The headrest optionally supplied for this mobility device by Invacare is perfectly suitable for use during transport.
- The headrest must be adjusted to the user's ear height.

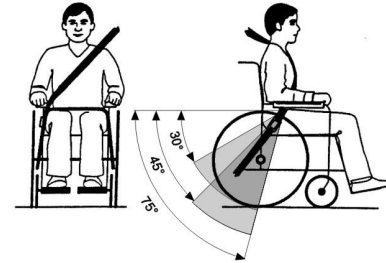

Fig. 8-9

The pelvic belt should be positioned in the area between the user's pelvis and thighs so that it is unobstructed and not too loose. The ideal angle of the pelvic belt to the horizontal is between 45° and 75°. The maximum permissible angle is between 30° and 75°. The angle should never be less than 30°!

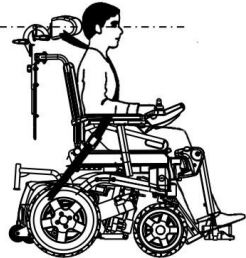

Fig. 8-7



Fig. 8-8

Seat belts may not be held at a distance from the user's body using parts of the mobility device such as armrests or wheels.

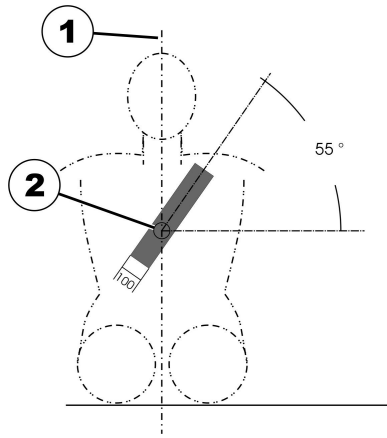

Fig. 8-10

The safety belt installed in the transporting vehicle should be applied as shown in the illustration above.

- 1) Center line of the body
- 2) Center of the sternum

## 8.6 Transporting the Mobility Device Without Occupant



### **CAUTION!** **Risk of injury**

- If you are unable to fasten your mobility device securely in a transport vehicle, Invacare recommends that you do not transport it.

Your mobility device may be transported without restrictions, whether by road, rail or by air. Individual transport

companies have, however, guidelines which can possibly restrict or forbid certain transport procedures. Please ask the transport company regarding each individual case.

- Before transporting your mobility device, make sure the motors are engaged and that the remote is switched off. Invacare strongly recommends that you disconnect or remove the batteries.
- Invacare strongly recommends securing the mobility device to the floor of the transporting vehicle.



## 9 Maintenance

### 9.1 Wear and Tear Information

#### General Information

Normal wear and tear items and components include but are not limited to: all upholstery items including seat and back upholstery, arm and calf pads, cushions, wheels, tires and casters, all types of batteries, joystick overlays and inductive rubberized protective boots.

Invacare reserves the right to ask for any item back that has an alleged defect in workmanship. Refer to the Warranty section in this manual for specific warranty information.

Refer to the Inspection Checklists for proper preventative maintenance schedule.

This is just a general guideline and does not include items damaged due to abuse and misuse.

Product Type	Product Wear and Tear
Wheelchairs	Wheels, Brake Assembly, Hand Grips
Mobility Hardware and Electronics	Rubber Urethane Tires and Casters, Handgrips, Joystick Inductive Tops, Joystick Overlays, Motors and Gearboxes (if exposed to prolonged moisture, urine, etc.), Stability Lock cylinders, Pneumatic Tires and Tubes

Upholstery and Seating	Arm pads, Seat Cushion Foam, Seat Cushion Covers, Back Cushion Foam, Back Cushion Covers, Headrest Foam, Headrest Covers, Footplate Covers, Calf Pad (if applicable) Foam and Cover
Batteries	Lead acid/Lithium, Coin cell (watch type), Gel (6 months)

### 9.2 User/Attendant Inspection Checklists



Every six months, and as necessary, take your wheelchair to a qualified technician for a thorough inspection and servicing.

Weekly, monthly, and periodic inspections should be performed by user/attendant between the six month service inspections.

Regular cleaning will reveal loose or worn parts and enhance the smooth operation of your wheelchair. To operate properly and safely, your wheelchair **MUST** be cared for just like any other vehicle. Routine maintenance will extend the life and efficiency of your wheelchair.

**DANGER!****Risk of Injury, Damage or Death**

Overinflation of tires may cause tires to explode.

- Inflate tire to the proper tire pressure (P.S.I. / kilopascals) listed on the side wall of the tire.
- Only use wheelchair with tires at proper pressure.
- The wheels and tires should be checked periodically for cracks and wear and should be replaced if necessary.

**9.2.1 Inspect/Adjust Weekly**

- Ensure that the casters are free of debris.
- Inspect tires for flat spots and wear.
- Inspect all fasteners.
- Inspect TRRO fasteners and hardware.
- Ensure proper operation of powered functions (Example: drive, seating and legrests).

**9.2.2 Inspect/Adjust Monthly**

- Clean upholstery and armrests.
- Clean dirt and lint from axles.
- Clean dirt and lint from bearings.
- Ensure that the casters are free of debris.
- Inspect seat positioning strap for any signs of wear. Ensure buckle latches. Verify hardware that attaches strap to frame is secure and undamaged. Replace if necessary.

**9.2.3 Inspect/Adjust Periodically**

- Ensure wheelchair rolls straight (no excessive drag or pull to one side).

- Inspect all operator (user/attendant) adjustable fasteners including the back pan, back cane and angle adjustment fasteners, and the arm support, flip back and height adjustment fasteners. Ensure fasteners are securely tightened.
- Inspect TRRO fasteners and hardware.
- Ensure clothing guards are secure.
- Ensure arms are secure but easy to release and adjustment levers engage properly.
- Ensure adjustable height arms operate and lock securely.
- Ensure upholstery does not have any rips or tears.
- Armrest pad sits flush against arm tube.
- Ensure that the casters are free of debris.
- Inspect foam handgrips for damage. If damaged, have them replaced by a qualified technician.
- Check center mount front riggings for loose fasteners. Replace /tighten if necessary.
- Check that all labels are present and legible. Replace if necessary.

**9.3 Service Inspection**

Every six months take your wheelchair to a qualified technician for a thorough inspection and servicing.

Service inspections **MUST** be performed by a qualified technician.

**DANGER!****Risk of Injury, Damage or Death**

- Overinflation of tires may cause tires to explode.
- Inflate tire to the proper tire pressure (P.S.I. / kilopascals) listed on the side wall of the tire.
  - Only use wheelchair with tires at proper pressure.
  - The wheels and tires should be checked periodically for cracks and wear and should be replaced if necessary.

**WARNING!****Risk of Serious Injury or Damage**

- Hardware that is loosely secured could cause loss of stability resulting in serious injury or damage.
- After ANY adjustments, repair or service and before use, make sure that all attaching hardware is tightened securely.

The following are recommended items to inspect during regular service inspections performed by a qualified technician. Actual items to be inspected during the service inspection may vary according to the specific wheelchair:

**9.3.1 Six Month Inspection****DANGER!****Risk of Death, Serious Injury, or Damage**

- Failure to complete the inspection of the critical components listed below could result in death or serious injury.
- Inspect stability control components which could include anti-dive spring, anti-dive cylinder, ratcheting gears, or end stops to ensure proper operation.
  - Inspect drive axle nut, locking tab, wheel fasteners or quick release to ensure drive wheel is secure

- Inspect stability lock cylinders, front and rear swing arms to ensure proper operation.
- Ensure adjustable height arms operate and lock securely.
- Ensure arms are secure but easy to release and adjustment levers engage properly.
- Inspect seat positioning strap for any signs of wear. Ensure buckle latches. Verify hardware that attaches strap to frame is secure and undamaged. Replace if necessary.
- Ensure axle nut or bolt and wheel mounting nuts are secure on drive wheels.
- Inspect tires for flat spots and wear.
- Loosen/tighten caster locknut if wheel wobbles noticeably or binds to a stop.
- Ensure all caster/wheel/fork/headtube fasteners are secure and not damaged/missing.
- Check center mount front riggings for loose fasteners. Replace /tighten if necessary.

- Cables shall be inspected periodically to ensure that they are routed and secured properly. Periodic inspection is recommended as it may reveal loose and/or damaged cables. Re-secure all loose cables and replace by following the recommendations outlined in the LiNX Controls System Service Manual.
- Ensure proper operation of powered functions (drive, seating, legrests, etc.).
- Inspect gearbox coupling.
- Inspect electrical components for signs of corrosion. Replace if corroded or damaged.
- Inspect battery terminals for loose cable connection. Tighten if necessary.
- Ensure swingarm stops are in place and not deteriorated or damaged. Replace if necessary.
- Clean upholstery and armrests.
- Clean dirt and lint from axles.
- Clean dirt and lint from bearings.
- Check that all labels are present and legible. Replace if necessary.
- Ensure clothing guards are secure.
- Ensure upholstery does not have any rips or tears.
- Ensure armrest pad sits flush against arm tube.
- Ensure wheelchair rolls straight (no excessive drag or pull to one side).
- Ensure that the casters are free of debris.
- Inspect all fasteners including the back pan, back cane and angle adjustment fasteners, and the arm support, flip back and height adjustment fasteners. Ensure fasteners are securely tightened.
- Inspect TRBKTS fasteners and hardware.
- Inspect foam handgrips for damage. If damaged, have them replaced by a qualified technician.

### 9.3.2 Replace Every 18 Months

Replace gearbox coupling.

### 9.3.3 Replace Every 2 Years

The stability locking cylinders MUST be replaced every two years.

## 9.4 Cleaning



### **WARNING!**

#### **Risk of Injury, Damage or Death**

Electrical shock may cause injury, damage or death.

- Always unplug the product from the electrical outlet before cleaning.
- Always unplug accessories from the electrical outlet before cleaning.



### **CAUTION!**

#### **Risk of Damage**

Cleaning or maintenance may cause damage to carpeting or flooring.

- Place the wheelchair in a well ventilated area where cleaning or maintenance can be performed without risk of damage to carpeting or flooring.

**CAUTION!****Risk of Damage**

Exposure to liquids may damage components or accessories of wheelchair and electronics.

- DO NOT spray with any type of water or liquid.
- Electrical components damaged by corrosion MUST be replaced immediately.

**WARNING!****Risk of Injury, Damage or Death**

Excessive moisture or cleaning may reduce the flame retardancy of the upholstery and may result in injury, damage or death.

- Follow all cleaning instructions.
- Avoid excessive moisture or cleaning.



Regular cleaning will reveal loose or worn parts and enhance the smooth operation of your wheelchair. To operate properly and safely, your wheelchair must be cared for just like any other vehicle.

For upholstery that is severely stained or surface finish that is badly damaged, contact Invacare for further information.

1. Use the following instructions to clean this product unless otherwise specified.
  - Upholstery — Warm water and mild non-abrasive soap.
  - Metal — Hot water and mild non-abrasive soap. Car polish and soft wax may be used to remove abrasions and restore gloss.
  - Plastic — Hot water and mild non-abrasive soap.
2. Dry the surface with dry cloth.
3. DO NOT use solvents or kitchen cleaners.

## 9.5 Stability Lock

**DANGER!****Risk of Death or Serious Injury**

Not performing periodic maintenance on stability lock could result in death or serious injury.

- ALWAYS perform the periodic maintenance to the stability lock listed in the inspection checklist of this manual.

Stability Lock uses one-way, gas locking cylinders that engage if the rear casters begin to lift off the ground, preventing the chair from lurching forward.

## 9.6 Removing/Installing the Shrouds



### CAUTION!

- Place the wheelchair in a well ventilated area where work can be performed without risking damage to carpeting or floor covering.

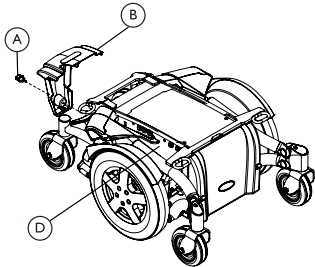

Fig. 9-1 Removing/Installing the Rear Shroud

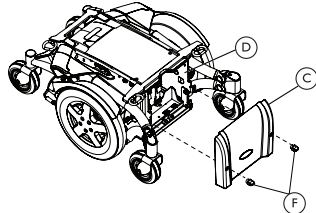

Fig. 9-2 Removing/Installing the Front Shroud

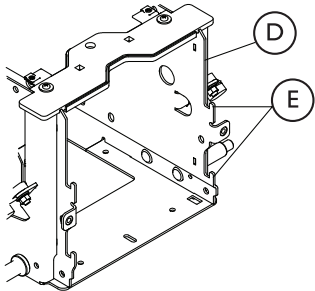

Fig. 9-3 Hooks on the Wheelchair Frame

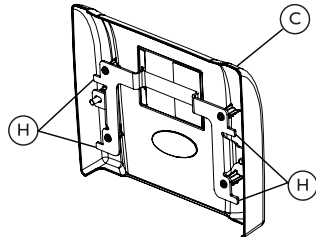

Fig. 9-4 Front Shroud Detail

### 9.6.1 Removing the Rear Shroud

1. Verify the joystick On/Off switch is in the Off position.
2. Remove the knob screw (A) that secures the rear shroud (B) to the base frame (C).
3. Remove the rear shroud from the base frame.

### 9.6.2 Installing the Rear Shroud

1. Install the rear shroud (B) and secure in place with knob screw (A).

### 9.6.3 Removing/Installing the Front Shroud/Battery Retention Bracket

#### Removing

The front shroud/battery retention bracket (C) is removed from and installed onto the wheelchair frame (D) as a single unit.





Front shroud/battery retention bracket (C) mounts on hooks (E) located on the wheelchair frame (D).





Have the following tools available: 1/4 inch Allen Wrench, 7/16 inch Box Wrench.

1. Remove the mounting screws (F) securing the front shroud/battery retention bracket to the wheelchair frame (D).
2. Lift up to unhook the front shroud/battery retention bracket from the base frame and remove.

## Installing

 When performing STEP 1, ensure that the tabs  located on the sides of the front shroud/battery retention bracket  are positioned on the hooks  located on the front of the wheelchair frame .

1. Reinstall the front shroud/battery retention bracket onto front of wheelchair frame.
2. Secure the front shroud/battery retention bracket  to the wheelchair frame  with two mounting screws . Securely tighten.
3. Gently, pull on the front shroud to ensure the mounting screws are fully engaged into the battery box.

## 9.7 Wheels and Tires

### Damaged Wheels

In case of having a damaged wheel, contact your provider. For safety reasons, do not repair the wheel yourself or have the wheel repaired by unauthorized persons.

### Pneumatic Tires



#### **DANGER!**

#### **Risk of Injury, Damage or Death**

Overinflation of tires may cause tires to explode.

- Inflate tire to the proper tire pressure (P.S.I. / kilopascals) listed on the side wall of the tire.
- Only use wheelchair with tires at proper pressure.
- The wheels and tires should be checked periodically for cracks and wear and should be replaced if necessary.



#### **Risk of damage to tire and rim**

Never drive with under-inflated tires, this could result in damage to tire.  
If tire pressure is exceeded rim could be damaged.  
– Inflate tires to recommended pressure.



Use tire gauge to check pressure.

Check weekly that the tires are inflated to the correct pressure, see chapter 9.2 *User/Attendant Inspection Checklists*, page 65.

For recommended tire pressure see inscription on tire/rim or contact Invacare. Compare table below for conversion.

psi	bar
22	1.5
23	1.6
25	1.7
26	1.8
28	1.9
29	2.0
30	2.1
32	2.2
33	2.3
35	2.4
36	2.5

Invacare® TDX® SP2 Series

<b>psi</b>	<b>bar</b>
38	2.6
39	2.7
41	2.8
44	3.0



---

## 10 After Use

---

### 10.1 Reuse

The product is suitable for reuse. To recondition the product for a new user, carry out the following actions:

- Clean the product. Refer to *9 Maintenance, page 65*.
- Inspection according to service plan. Consult service instructions, available from Invacare.
- Adaptation to the user. Refer to *5 Setup, page 39*.

### 10.2 Disposal



Fig. 10-1

- The equipment wrapping is potentially recyclable.
- The metal parts are used for scrap metal recycling.
- The plastic parts are used for plastic recycling.
- Electric components and printed circuit boards are disposed of as electronic scrap.
- Old, used or damaged batteries are hazardous material and MUST be recycled through an approved agency. Discarding these batteries in the trash is considered improper disposal and is unlawful in many locations. Contact your provider or Invacare for proper disposal and recycling of your batteries.

- Disposal must be carried out in accordance with the respective national legal provisions.
- Ask your city or district council for details of the local waste management companies.

## 11 Troubleshooting

### 11.1 Driving Performance

	Solutions		
	Check casters for loose or overtightened stem nuts/bolts, bearings or signs of wear.	Check for uneven tire wear, bent fork/frame or loose hardware.	If pneumatic, check tires for correct and equal pressure.
Wheelchair Veers Left or Right	X	X	X
Sluggish Turn or Performance	X		X
Casters Flutter	X	X	X
Squeaks and Rattles		X	
Looseness in Wheelchair		X	X
Wheelchair 3 Wheels		X	X

### 11.2 Control System



For additional troubleshooting information and explanation of error codes, refer to the individual remote (joystick) manual supplied with each wheelchair.

SYMPTOM	PROBABLE CAUSE	SOLUTIONS
Batteries draw excessive current when charging.	Battery failure. Electrical malfunction.	Have batteries checked for shorted cell. Replace if necessary.  Contact Provider/Invacare for service.
Battery indicator flashes the charge level is low - immediately after recharge.	Battery failure. Malfunctioning battery charger. Electrical malfunction.	Check batteries for shorted cell. Replace if necessary.  Contact Provider/Invacare for Service.  Contact Provider/Invacare for Service.

SYMPTOM	PROBABLE CAUSE	SOLUTIONS
Battery indicator flashes the charge level is low - too soon after being recharged.	Batteries not charged. Weak batteries.	Have charger checked. Replace batteries if necessary. Refer to 7.2.14 <i>Replacing Batteries and/or Battery Cables, page 54.</i>
Motor “chatters” or runs irregular.	Motor/gearbox malfunction.	Stop use of Wheelchair. Contact Provider/Invacare for Service.
Joystick erratic or does not respond as desired.	Damaged motor coupling. Electrical malfunction. Controller programmed improperly.	Contact Provider/Invacare for Service. Contact Provider/Invacare for Service. Contact Provider/Invacare to have controller reprogrammed.

SYMPTOM	PROBABLE CAUSE	SOLUTIONS
Wheelchair does not respond to commands.	Electrical malfunction.	Contact Provider/Invacare for Service.
Power indicator off - even after recharging.	Poor battery terminal connection.	Have terminals cleaned.

### 11.2.1 Battery and Charger Tips

The following “Do’s” and “Don’ts” are provided for your convenience and safety.

DON'T	DO
Don't perform any installation or maintenance without first reading this manual.	Read and understand this manual and any service information that accompanies a battery and charger before operating the wheelchair.
Don't perform installation or maintenance of batteries in an area that could be damaged by battery spills.	Move the wheelchair to a work area before cleaning terminals, or opening battery box.
Don't make it a habit to discharge batteries to the lowest level.	Recharge as frequently as possible to maintain a high charge level and extend battery life.

<b>DON'T</b>	<b>DO</b>
Don't use randomly chosen batteries or chargers.	Follow recommendations in this manual when selecting a battery or charger.
Don't put new batteries into service before charging.	Fully charge a new battery before using.
Don't tip or tilt batteries.	Use a carrying strap to remove, move or install a battery.
Don't tap on clamps and terminals with tools.	Push battery clamps on the terminals. Spread clamps wider if necessary.
Don't mismatch your battery and chargers.	Use only a gel charger for a gel battery.

## 12 Technical Data

### 12.1 Technical Specifications

The technical information provided hereafter applies to a standard configuration or represents maximum achievable values. These can change if accessories are added. The precise changes to these values are detailed in the sections for the respective accessories.

 Note that in some cases the measured values may vary up to  $\pm .50$  inches ( $\pm 10$  mm).

Permissible operating and storage conditions	
Temperature range for operation according to ISO 7176-9:	<ul style="list-style-type: none"> <li>-13 <math>\pm</math> 9 °F (-25 <math>\pm</math> 5 °C) ... 122 <math>\pm</math> 9 °F (+50 <math>\pm</math> 5 °C)</li> </ul>
Recommended storage temperature:	<ul style="list-style-type: none"> <li>59 <math>\pm</math> 9 °F (+15 <math>\pm</math> 5 °C)</li> </ul>
Temperature range for storage according to ISO 7176-9:	<ul style="list-style-type: none"> <li>-13 <math>\pm</math> 9 °F (-25 <math>\pm</math> 5 °C) ... 149 <math>\pm</math> 9 °F (+65 <math>\pm</math> 5 °C) with batteries</li> <li>-58 <math>\pm</math> 9 °F (-40 <math>\pm</math> 5 °C) ... 149 <math>\pm</math> 9 °F (+65 <math>\pm</math> 5 °C) without batteries</li> </ul>

Charging device	
Output current	<ul style="list-style-type: none"> <li>8 A <math>\pm</math> 8 % off board charger (110 V)</li> </ul>
Output voltage	<ul style="list-style-type: none"> <li>24 V nominal</li> </ul>

Base Configuration	Center Wheel Drive
Suspension	Enhanced SureStep® Suspension
Motors	<ul style="list-style-type: none"> <li>Durawatt™ 4-pole SSD</li> <li>Power: 24V DC/324 W at 13.5 Amps</li> <li>Voltage: 24 V nominal</li> </ul>
Motor Gearbox Sound Level	54dBa

Batteries	<ul style="list-style-type: none"> <li>• Number: 2</li> <li>• Type: GP24 or 22NF</li> <li>• Chemistry: Sealed VRLA Gel</li> <li>• Operating Voltage: 24V nominal (2 x 12 V)</li> <li>• GP24 Battery weight: approximately 52 lbs (23.6 kg) per battery</li> <li>• 22NF Battery weight: approximately 37 lbs (16.8 kg) per battery</li> <li>• GP24 Amp-Hour Rating: 73.5 Ah (C20) (63 Ah (C5))</li> <li>• 22NF Amp-Hour Rating: 50 Ah (C20) (43.2 Ah (C5))</li> <li>• Fuse: 125 A</li> </ul>
Degree of protection <sup>1</sup>	<ul style="list-style-type: none"> <li>• Power Wheelchair Base — IPX4</li> <li>• Charger — IPX1</li> </ul>
Drive wheels	<ul style="list-style-type: none"> <li>• Black with rim inserts, 14 x 3"</li> <li>• Black tires with gel foam inserts or pneumatic tires</li> </ul> <p> The recommended maximum tire pressure in bar or kpa is marked on the side wall of the tire or the rim. If more than one value is listed, the lower one in the corresponding units applies.</p> <p>(Tolerance = -0.3 bar, 1 bar = 100 kpa)</p>
Forks	Single and double sided forks
Casters	<ul style="list-style-type: none"> <li>• Black, 6 x 2"</li> <li>• Puncture proof</li> </ul>

<b>Driving characteristics</b>	
Maximum Speed	<ul style="list-style-type: none"> <li>• 5.8 mph (9.3 km/h)</li> </ul>
Minimum braking distance	<ul style="list-style-type: none"> <li>• 5.8 mph (9.3 km/h): 45.7–69.3 in (1161–1760 mm)</li> </ul>
Minimum braking time	<ul style="list-style-type: none"> <li>• 5.8 mph (9.3 km/h): 1.39 sec</li> </ul>

<b>Driving characteristics</b>	
Rated slope <sup>2</sup>	<ul style="list-style-type: none"> <li>• 9° (15.8 %) according to manufacturer's specifications with 300 lb (136 kg) payload, 4° seat angle, 20° backrest angle</li> </ul>
Maximum climbable obstacle height	<ul style="list-style-type: none"> <li>• 2.95 in (75 mm) Forward</li> <li>• 0.98 in (25 mm) Reverse</li> </ul>
Turning diameter	<ul style="list-style-type: none"> <li>• 50.4 in (1120 mm) — 65.4 in (1661 mm) depending on seat configuration</li> </ul>
Turning width	<ul style="list-style-type: none"> <li>• 42.72 in (1085 mm)</li> </ul>
Pivot width	<ul style="list-style-type: none"> <li>• 53.15 in (1350 mm)</li> </ul>
Drive range in accordance with ISO 7176-4 <sup>3</sup>	<ul style="list-style-type: none"> <li>• 22NF batteries: 13.7 mi (22 km)</li> <li>• GP24 batteries: 20.7 mi (33 km)<sub>4</sub></li> </ul>

<b>Dimensions according to ISO 7176-15</b>	
Overall height (without headrest)	<ul style="list-style-type: none"> <li>• 42.5–47.6 in (1080–1210 mm)</li> <li>• 42.5–60.4 in (1080–1535 mm)</li> </ul>
Overall height (with elevate and headrest)	<ul style="list-style-type: none"> <li>• 43 in (1100 mm)</li> </ul>
Maximum base width	<ul style="list-style-type: none"> <li>• 22NF batteries: 24 in (615 mm)<sup>4</sup></li> <li>• GP24 batteries: 25.5 in (650 mm)</li> </ul>
Total length (including center-mounted front rigging)	<ul style="list-style-type: none"> <li>• 45.3 in (1160 mm) at 0°</li> </ul>
Base length (without legrests)	<ul style="list-style-type: none"> <li>• 31.5 in (800 mm) — 45.3 in (1160 mm)</li> </ul>
Ground clearance	<ul style="list-style-type: none"> <li>• &gt; 2.5 in (70 mm)</li> </ul>
Horizontal location of axle <sup>7</sup>	<ul style="list-style-type: none"> <li>• 8.66–4.72 in (350 – 280 mm)</li> </ul>

<b>Weight<sup>8</sup></b>	
Base weight without 22NF batteries	152 lbs (69 kg)
Base weight without GP24 batteries	161 lbs (73 kg)

**WARNING!****Risk of Death or Serious Injury**

Exceeding the weight capacity of the wheelchair/seating system could cause instability resulting in death or serious injury.

– DO NOT exceed the weight capacity.

<b>Weight Capacity/Payload</b>	
Maximum weight capacity/payload <sup>9</sup>	<ul style="list-style-type: none"> <li>• Non-Elevate—up to 300 lbs (136 kg)</li> <li>• Elevate—up to 250 lbs (113 kg)</li> </ul> <p> Weight limitation is total weight (user weight plus any additional items that the user may require [back pack, ventilator, etc.]). Example: If weight limitation of the wheelchair is 300 lbs and additional items equal 25 lbs, subtract 25 lbs from 300 lbs. This means the maximum weight limitation of the user is 275 lbs.</p>

<b>Axle loads</b>	
Maximum front axle load	<ul style="list-style-type: none"> <li>• 233.7 lbs (106 kg)</li> </ul>
Maximum rear axle load	<ul style="list-style-type: none"> <li>• 213.85 lbs (97 kg)</li> </ul>
Maximum center axle load	<ul style="list-style-type: none"> <li>• 478.4 lbs (217 kg)</li> </ul>



- 1 IPX4 classification means that the electrical system is protected against spray water.  
IPX1 classification means that the charger is protected against vertically falling drops of water.
- 2 Static stability downhill, uphill, and sideways according to ISO 7176-1 = 9° (15.8 %)  
Dynamic stability uphill according to ISO 7176-2 = 6° (10.5 %)
- 3 Note: The drive range of a mobility device is strongly influenced by external factors, such as the speed setting of the wheelchair, the charging state of the batteries, surrounding temperature, local topography, road surface characteristics, tire pressure, weight of user, drive style and use of batteries for lighting, servos etc.  
The specified values are theoretical maximum achievable values measured according to ISO 7176-4.
- 4 Measured with solid tires. Pneumatic tires can increase the maximum total width.
- 5 Measured without seat cushion
- 7 Horizontal distance of wheel axle from intersection of loaded seat and backrest reference planes
- 8 The actual curb weight depends on the options and accessories your mobility device has been supplied with. Every Invacare mobility device is weighed when leaving the factory. Refer to the invoice for the curb weight (including batteries) measured.
- 9 If two values are possible the lowest always applies.

## 12.2 ISO 7176-15 Annex A

### Information Disclosure in Manufacturer’s Specification Sheets

Manufacturer: Invacare Corporation

Address: 1200 Taylor Street, Elyria, OH 44035

Model: TDX-SP2 (LiNX and Ultra Low Maxx Seat)

Maximum occupant mass:

- Non-Elevate—300 lb (136 kg)
- Elevate—250 lb (113 kg)

Disclosure Information (ISO)	TDX-SP2	
	Minimum	Maximum
Overall length with legrest	44 in (1120 mm)	50 in (1265 mm)
Overall width	29 in (730 mm)	35 in (900 mm)

Disclosure Information (ISO)	TDX-SP2	
	Minimum	Maximum
Folded length	N/A*	N/A*
Folded width	N/A*	N/A*
Folded height	N/A*	N/A*
Total mass	330 lb (150 kg)	450 lb (204 kg)
Mass of heaviest part	37 lb (17 kg)	52 lb (24 kg)
Static stability downhill	14°	21°
Static stability uphill	13°	21°
Static stability sideways	14°	20°
Energy consumption	14 mi (22 km)	20.6 mi (33 km)
Dynamic stability uphill	9°	9°
Obstacle climbing	0.98 in (25 mm)	2.95 in (75 mm)
Maximum speed forward	5.8 mph (9.3 km/h)	5.8 mph (9.3 km/h)
Minimum braking distance from max speed	45.7 in (1161 mm)	69.3 in (1760 mm)
Seat plane angle	0°	55°
Effective seat depth	16 in (405 mm)	23 in (585 mm)
Effective seat width	16 in (405 mm)	22 in (559 mm)

Disclosure Information (ISO)	TDX-SP2	
	Minimum	Maximum
Seat surface height at front edge	17.25 in (438 mm)	20.5 in (521 mm)
Backrest angle	82°	168°
Backrest height	18 in (457 mm)	27 in (686 mm)
Footrest to seat distance	13.4 in (340 mm)	16.1 in (410 mm)
Leg to seat surface angle	97°	-7°
Armrest to seat distance	9 in (230 mm)	18.75 in (476 mm)
Front location of armrest structure	10 in (254 mm)	23 in (590 mm)
Handrim diameter	N/A**	N/A**
Horizontal location of axle	7 in (178 mm)	8.5 in (216 mm)
Minimum turning radius	20 in (508 mm)	-
<p>The wheelchair conforms to the following standards:</p> <p>a) requirements and test methods for static, impact and fatigue strengths (ISO 7176-8)</p> <p style="text-align: right;">YES</p>		

Disclosure Information (ISO)	TDX-SP2	
	Minimum	Maximum
b) power and control systems for electric wheelchairs — requirements and test methods (ISO 7176–14)		YES
c) climatic test in accordance with ISO 7176–9		YES
d) requirements for resistance to ignition in accordance with ISO 7176–16		YES

 The requirements in this annex which apply are only those that are relevant to the specific wheelchair being disclosed. For example, parts of the table apply only to powered wheelchairs and therefore would not apply to manual wheelchairs.

\* Folded length, Folded width and Folded height are only required for wheelchairs which have folding frames.

\*\* Handrim diameter is only required for wheelchairs with handrims as an option.

---

## 13 Warranty

---

### 13.1 Limited Warranty—US

Except as otherwise set forth below, Invacare warrants that the following components of the mobility device (“product”) will be free from defects in materials and workmanship for a period of one (1) year from the date Invacare ships the product to the original purchaser or provider: base frame, electronics and electrical components (excluding batteries), motors, powered seating actuators, gearboxes, bearings and bushings, seat frame, fixed seat post, upholstered materials, padded materials, casters, tires and tubes (excluding normal wear and tear). Invacare warrants all product batteries will be free from defects in materials and workmanship for a period of six (6) months from the date Invacare ships the product to the original purchaser or provider. The warranties described above are referred to as the “Warranty”. A copy of the original product invoice is required for coverage under the Warranty.

### 13.2 Limited Warranty—Canada

Except as otherwise set forth below, Invacare warrants the base frame of the mobility device (“product”) will be free from defects in materials and workmanship for a period of five (5) years from the date Invacare ships the product to the original purchaser or provider. Invacare warrants that the seat frame and fixed seat post will be free from defects in materials and workmanship for a period of three (3) years from the date Invacare ships the product to the original purchaser or provider. Invacare warrants that the following components of the product will be free from defects in materials and workmanship for a period of two

(2) years from the date Invacare ships the product to the original purchaser or provider: electronics and electrical components (excluding batteries), motors, powered seating actuators, gearboxes. Invacare warrants that the following components of the product will be free from defects in materials and workmanship for a period of one (1) year from the date Invacare ships the product to the original purchaser or provider: bearings and bushings, upholstered materials (excluding normal wear and tear), padded materials (excluding normal wear and tear), brake pads (excluding normal wear and tear), casters (excluding normal wear and tear), tires and tubes (excluding normal wear and tear). Invacare warrants all product batteries will be free from defects in materials and workmanship for a period of six (6) months from the date Invacare ships the product to the original purchaser or provider. The warranties described above are referred to as the “Warranty”. A copy of the original product invoice is required for coverage under the Warranty.

### 13.3 Repair or Replacement

Invacare's sole obligation and the original purchaser's exclusive remedy under the Warranty is limited to Invacare's repair and/or replacement, at Invacare's option, of defective components and batteries covered by the Warranty. Such repair or replacement does not include any labor or shipping charges incurred by Invacare in the replacement and/or repair of any such component or battery. For Warranty service, please contact the provider from whom you purchased your product. In the event you do not receive satisfactory Warranty service, please write directly to Invacare at the address on the bottom of the back cover. Provide provider's name address, date of purchase, indicate

nature of the defect and, if the product is serialized, indicate the serial number. Do not return products to Invacare without Invacare's prior written authorization.

### **13.4 Limitations and Exclusions**

The Warranty is extended only to the original purchaser who purchases the product new and unused from Invacare or a provider. The Warranty is not extended to any other person or entity and is not transferable or assignable to any subsequent purchaser or owner. Coverage under the Warranty will end upon any such subsequent sale or other transfer of title to any other person.

The Warranty does not apply to serial numbered products if the serial number has been removed or defaced, products subject to neglect, abuse, accident, improper operation, maintenance or storage, commercial or fleet use, products modified without Invacare's express written authorization (including, but not limited to, modification through the use of unauthorized parts or attachments), products damaged by reason of repairs made to any component without Invacare's express written authorization, or to a product damaged by circumstances beyond Invacare's control, and such evaluation will be solely determined by Invacare.

The Warranty does not apply to problems arising from normal wear and tear or failure to adhere to the product instructions. A change in operating noise, particularly relative to motors and gearboxes does not constitute a failure or defect and will not be repaired or replaced as all products are expected to exhibit changes in operating noise due to aging.

### **13.5 Disclaimers**

The Warranty may not be modified or waived in any manner whatsoever without Invacare's express written authorization.

THE WARRANTY IS EXCLUSIVE AND IN LIEU OF ANY OTHER WARRANTIES, WHETHER EXPRESS OR IMPLIED, STATUTORY OR OTHERWISE, INCLUDING WITHOUT LIMITATION, THE IMPLIED WARRANTIES OF MERCHANTABILITY AND FITNESS FOR A PARTICULAR PURPOSE.

EXCEPT AND TO THE EXTENT AS MAY BE PROHIBITED BY STATE OR PROVINCIAL LAW, IN NO EVENT SHALL INVACARE BE LIABLE FOR ANY DIRECT, INDIRECT, SPECIAL, INCIDENTAL OR CONSEQUENTIAL DAMAGES RESULTING FROM OR ARISING OUT OF OR RELATED TO A DEFECT IN ANY PRODUCT, OR INVACARE'S PERFORMANCE OR FAILURE TO PERFORM ANY OF ITS OBLIGATIONS UNDER THIS WARRANTY, WHETHER OR NOT INVACARE HAS BEEN ADVISED, KNEW OR SHOULD HAVE KNOWN OF THE POSSIBILITY OF SUCH DAMAGES, INCLUDING, BUT NOT LIMITED TO, LOST PROFITS.





## Invacare Corporation

### Canada

570 Matheson Blvd E Unit 8  
Mississauga Ontario, L4Z 4G4  
Canada  
Tel: 800-668-5324  
[www.invacare.ca](http://www.invacare.ca)

### USA

One Invacare Way  
Elyria, Ohio USA  
44035  
Tel: 440-329-6000  
Tel: 800-333-6900  
[www.invacare.com](http://www.invacare.com)



60101831-B 2017-09-05



### New Zealand

Invacare New Zealand Ltd  
4 Westfield Place, Mt Wellington 1060  
New Zealand  
Tel: 0800 468 222  
[www.invacare.co.nz](http://www.invacare.co.nz)

### Australia

Invacare Australia PTY. Ltd.  
1 Lenton Place, North Rocks NSW 2151  
Australia  
Tel: 1800 460 460  
[www.invacare.com.au](http://www.invacare.com.au)



### Manufacturer:

Invacare Corporation  
1200 Taylor Street  
Elyria, Ohio USA  
44035

**Making Life's Experiences Possible®**



**Yes, you can.®**